

Service
Service
Service



Service Manual



TABLE OF CONTENTS

Handling Chip Components and Safety1 - 1
 Technical Specification & Service tools2 - 1
 Service Measurement.....2 - 2

Connections and controls3 - 1 to 3- 2
 Instructions for Use3 - 3 to 3 - 8

Disassembly Diagram.....4 - 1
 Pin-description of ICs4 - 2 to 4 - 5

Block Diagram5 - 1
 Wiring Diagram6 - 1

Tuner Board
 Circuit Diagram.....7 - 1
 Layout Diagram7 - 2
 Tuner Adjustment7 - 2

Main Board
 Circuit Diagram8 - 1
 Layout Diagram8 - 2

Cassette Board
 Circuit Diagram.....9 - 1
 Layout Diagram9 - 2

VCD Board
 Circuit Diagram.....10 - 1
 Layout Diagram
 Copper side view10 - 2
 Component side view10 - 3

Exploded Views Diagram
 Cabinet11 - 1
 Tape Deck11 - 2

Mechanical Partslist.....11 - 2
 Electrical Partslist12 - 1 to 12 - 2



© Copyright 2001 Philips Consumer Electronics B.V. Eindhoven, The Netherlands
 All rights reserved. No part of this publication may be reproduced, stored in a retrieval system or transmitted, in any form or by any means, electronic, mechanical, photocopying, or otherwise without the prior permission of Philips.

Published by LX 0234 Service Audio Printed in The Netherlands Subject to modification

GB 3140 785 32170



PHILIPS

HANDLING CHIP COMPONENTS

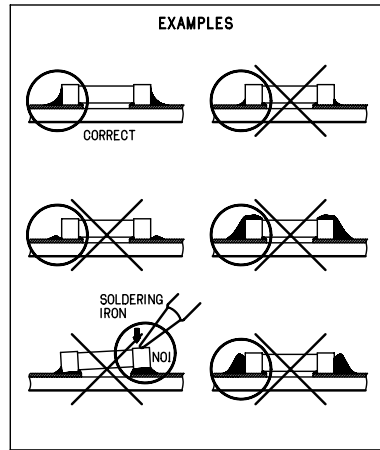
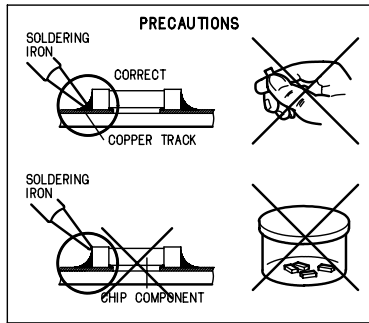
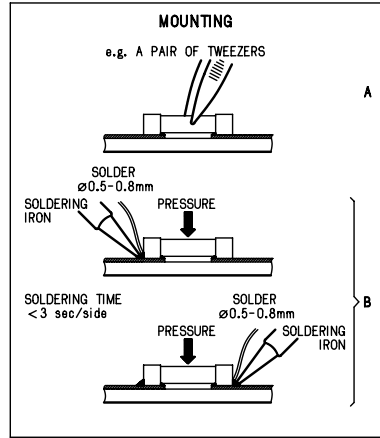
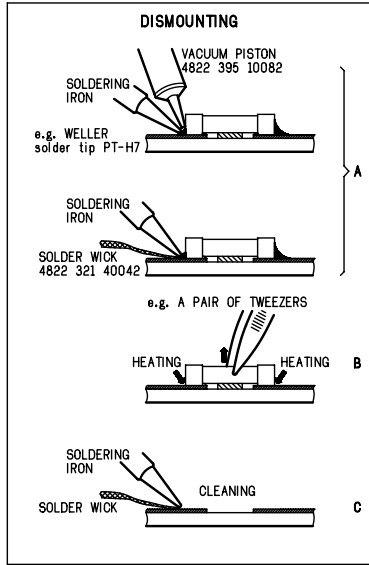
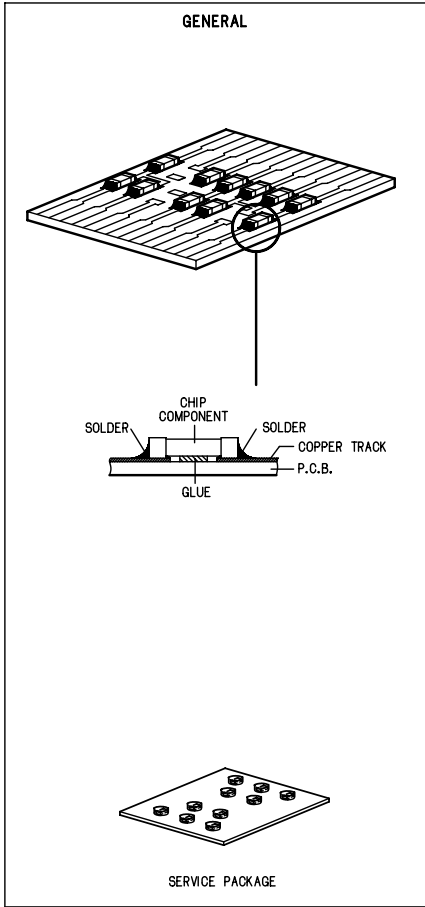

(GB) WARNING

All ICs and many other semiconductors are susceptible to electrostatic discharges (ESD). Careless handling during repair can reduce life drastically. When repairing, make sure that you are connected with the same potential as the mass of the set via a wristband with resistance. Keep components and tools at this potential.

ESD



(NL) WAARSCHUWING

Alle IC's en vele andere halfgeleiders zijn gevoelig voor electrostatische ontladingen (ESD). Onzorgvuldig behandelen tijdens reparatie kan de levensduur drastisch doen verminderen. Zorg ervoor dat u tijdens reparatie via een polsband met weerstand verbonden bent met hetzelfde potentiaal als de massa van het apparaat. Houd componenten en hulpmiddelen ook op ditzelfde potentiaal.

(F) ATTENTION

Tous les IC et beaucoup d'autres semi-conducteurs sont sensibles aux décharges statiques (ESD). Leur longévité pourrait être considérablement écourtée par le fait qu'aucune précaution n'est prise à leur manipulation. Lors de réparations, s'assurer de bien être relié au même potentiel que la masse de l'appareil et enfilier le bracelet sert d'une résistance de sécurité. Veiller à ce que les composants ainsi que les outils que l'on utilise soient également à ce potentiel.

(D) WARNUNG

Alle ICs und viele andere Halbleiter sind empfindlich gegenüber elektrostatischen Entladungen (ESD). Unvorsichtige Behandlung im Reparaturfall kann die Lebensdauer drastisch reduzieren. Sorgen Sie dafür, daß Sie im Reparaturfall über ein Pulsarmband mit Widerstand mit dem Massepotential des Gerätes verbunden sind. Halten Sie Bauteile und Hilfsmittel ebenfalls auf diesem Potential.

(I) AVVERTIMENTO

Tutti IC e parecchi semi-conduttori sono sensibili alle scariche statiche (ESD). La loro longevità potrebbe essere fortemente ridotta in caso di non osservazione della più grande cauzione alla loro manipolazione. Durante le riparazioni occorre quindi essere collegato allo stesso potenziale che quello della massa dell'apparecchio tramite un braccialeto a resistenza. Assicurarsi che i componenti e anche gli utensili con quali si lavora siano anche a questo potenziale.

(GB)

Safety regulations require that the set be restored to its original condition and that parts which are identical with those specified be used. Safety components are marked by the symbol ▲

(F)

Les normes de sécurité exigent que l'appareil soit remis à l'état d'origine et que soient utilisées les pièces de rechange identiques à celles spécifiées. Les composants de sécurité sont marqués ▲

SAFETY



(D)

Bei jeder Reparatur sind die geltenden Sicherheitsvorschriften zu beachten. Der Originalzustand des Gerätes darf nicht verändert werden. Für Reparaturen sind Originalersatzteile zu verwenden. Sicherheitsbauteile sind durch das Symbol ▲ markiert.

(NL)

Veiligheidsbepalingen vereisen, dat het apparaat in zijn oorspronkelijke toestand wordt teruggebracht en dat onderdelen, identiek aan de gespecificeerde, worden toegepast. De Veiligheidsonderdelen zijn aangeduid met het symbool ▲

(I)

Le norme di sicurezza estigono che l'apparecchio venga rimesso nelle condizioni originali e che siano utilizzati i pezzi di ricambio identici a quelli specificati. Componenti di sicurezza sono marcati con ▲

(GB) DANGER: Invisible laser radiation when open. AVOID DIRECT EXPOSURE TO BEAM.

(S) Varning ! Osynlig laserstrålning när apparaten är öppnad och spärren är urkopplad. Betrakta ej strålen.

(DK) Advarsel ! Usynlig laserstrålning ved åbning når sikkerhedsafbrydere er ude af funktion. Undgå udsættelse for stråling.

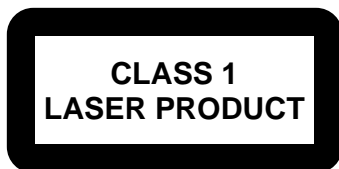

(FIN) Varoitus ! Avatussa laitteessa ja suojalukituksen ohitettaessa olet alttiina näkymättömälle laserisäteilylle. Älä katso säteeseen !

(GB) After servicing and before returning the set to customer perform a leakage current measurement test from all exposed metal parts to earth ground, to assure no shock hazard exists. The leakage current must not exceed 0.5mA.

(F) "Pour votre sécurité, ces documents doivent être utilisés par des spécialistes agréés, seuls habilités à réparer votre appareil en panne".

TECHNICAL SPECIFICATIONS

GENERAL

Mains voltage	-/01 : 120/230 V
Mains frequency	-/01 : 50 / 60 Hz
Battery	mains : 9 V (R14 x 6)
Power consumption	: 22 W
Dimension (W x H x D)	: 395 x 155 x 240 mm
Weight	: 3.1 Kg

AMPLIFIER

Output power	mains : 2 x 1 W
	battery : 2 x 1 W
Speaker impedance	: 2 x 8 ohm
Frequency response	: 70 Hz - 3 kHz (± 3 dB)

TUNER - FM SECTION

Tuning range	: 87 - 108.5 MHz
IF frequency	: 10.7 MHz ± 0.2 MHz
Sensitivity	: < 22 dB at 26dB S/N
Selectivity	: > 20 dB at ± 300 kHz
IF rejection	: > 50 dB
Image rejection	: > 20 dB

TUNER - MW SECTION

Tuning range	: 520 - 1630 kHz
IF frequency	: 455 kHz ± 3 kHz
Sensitivity	: < 4000 μ V/m at 26dB S/N
Selectivity	: > 16 dB
IF rejection ratio	: > 24 dB
Image rejection ratio	: > 28 dB

AUDIO CASSETTE RECORDER

Number of tracks	: 1 stereo
Tape speed	: 4.76 cm/sec $\pm 3\%$
Wow & flutter	: < 0.35 % JIS UWTD
Fast wind/rewind C60	: < 130 sec.
Frequency response	P/B : 125 - 8000 Hz
S/N ratio	: > 36 dB

COMPACT DISC

S/N ratio	: > 45 dB
Channel difference	1 kHz : < 3 dB
Channel crosstalk	1 kHz : > 26 dB
Laser wavelength	: 780 ± 20 nm
Laser light power	: < 0.3 mW

SERVICE TOOLS

Audio signal disc SBC 429.....	4822 397 30184
Playability test disc SBC 444.....	4822 397 30245
Test disc 5 (disc without errors) +	
Test disc 5A (disc with dropout errors, black spots and fingerprints)	
SBC 426/426A.....	4822 397 30096
Burn in test disc (65 min. 1kHz signal at -30 dB level without "pause").....	4822 397 30155

AVAILABLE ESD PROTECTION EQUIPMENT

anti-static table mat large 1200x650x1.25mm	4822 466 10953
small 600x650x1.25m	4822 466 10958
anti-static wristband	4822 395 10223
connection box (3 press stud connections, 1M Ω)	4822 320 11307
extendible cable (2m, 2M Ω , to connect wristband to connection box)	4822 320 11305
connecting cable (3m, 2M Ω , to connect table mat to connection box)	4822 320 11306
earth cable (1M Ω , to connect any product to mat or to connection box)	4822 320 11308
KIT ESD3 (combining all 6 prior products - small table mat)	4822 310 10671
wristband tester	4822 344 13999

SERVICE MEASUREMENT

Tuner SW

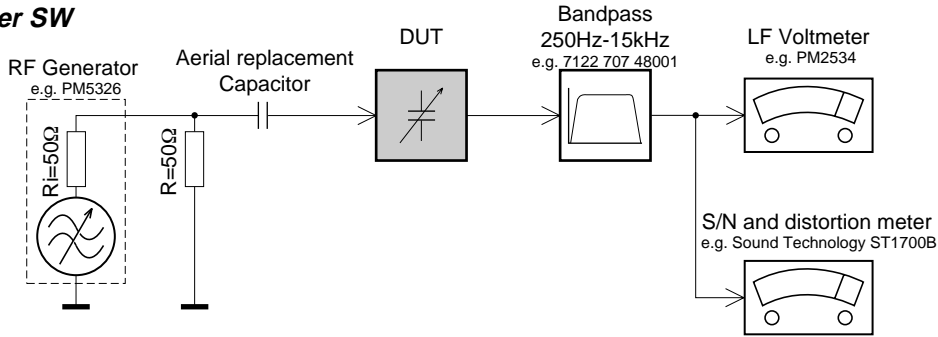

To avoid atmospheric interference all AM-measurements have to be carried out in a Faraday«s cage. Use a bandpass filter (or at least a high pass filter with 250Hz) to eliminate hum (50Hz, 100Hz).

Tuner AM (MW,LW)

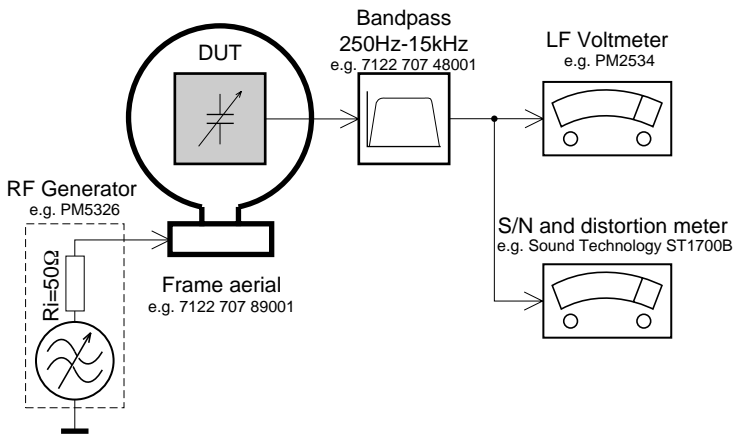

To avoid atmospheric interference all AM-measurements have to be carried out in a Faraday«s cage.

CD

Use Audio Signal Disc SBC429 4822 397 30184 (replaces test disc 3)
L.P.F. = 13th order filter 4822 395 30204

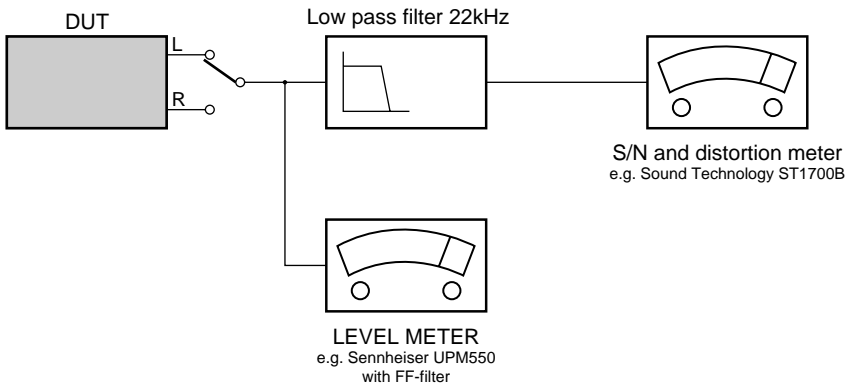

CONNECTIONS AND CONTROLS

MP3 General Information

Dear Customer,

Thank you for buying the Philips MP3-CD Soundmachine. Your great new acquisition will allow you to listen to up to 10 hours of CD-like quality music, using the revolutionary new music compression technology MP3.

MP3 technology

MP3 is short for MPEG1 Layer-3 encoding and decoding technology, a very powerful encoding algorithm with which you can shrink down the original Digital Audio sound data with a factor of up to 10 without losing significant sound quality.

Recording and Playback

It is recommended to set your recording bit rate to 128Kbps, sampling frequency at 44.1KHz to achieve CD-like music playback quality.

Since downloading MP3 files from the Internet, ripping songs from your own legal CD's and burning MP3 songs onto a CD-R, are a delicate process, the quality of a MP3 song may vary by these process. Subsequently, making a MP3-CD may not be entirely perfect.

As a result of the above imperfection, you may experience an occasional "skip" while listening, or an occasional delay in accessing "previous/next" title to MP3-CD's. This is considered to be normal.

A comparison chart is enclosed as below:

Sound Quality	Bit Rate	Approximate Reduction Ratio	Approximate total MP3-CD time	Comment
AM radio	32 kbps	40 : 1	40 hrs	Sound quality significantly affected-not recommended.
FM radio	64 kbps	20 : 1	20 hrs	
Near-CD	96 kbps	15 : 1	15 hrs	Balanced sound quality
CD-like	128 kbps	10 : 1	10 hrs	compression rate.
CD	256 kbps	5 : 1	5 hrs	Compression rate low
CD	320 kbps	3 : 1	3 hrs	suggest to play CDs instead.

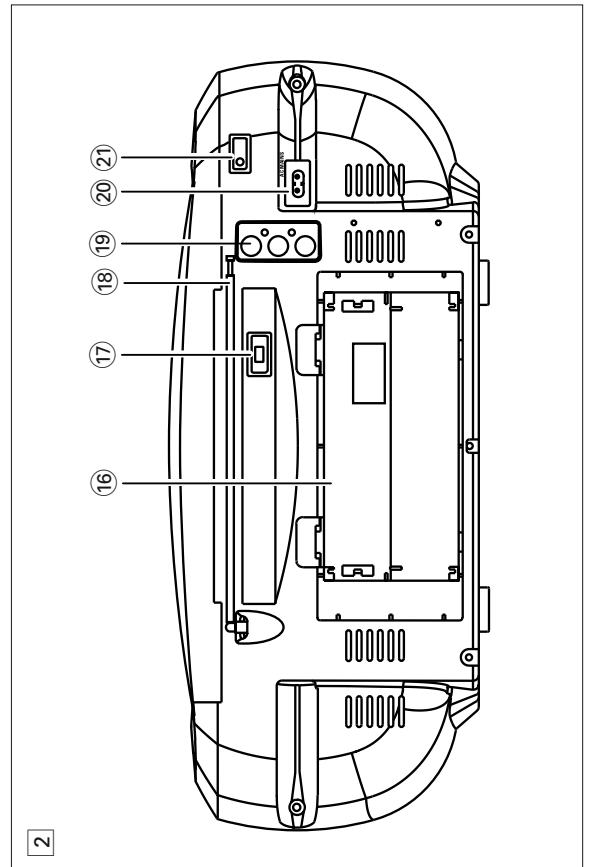
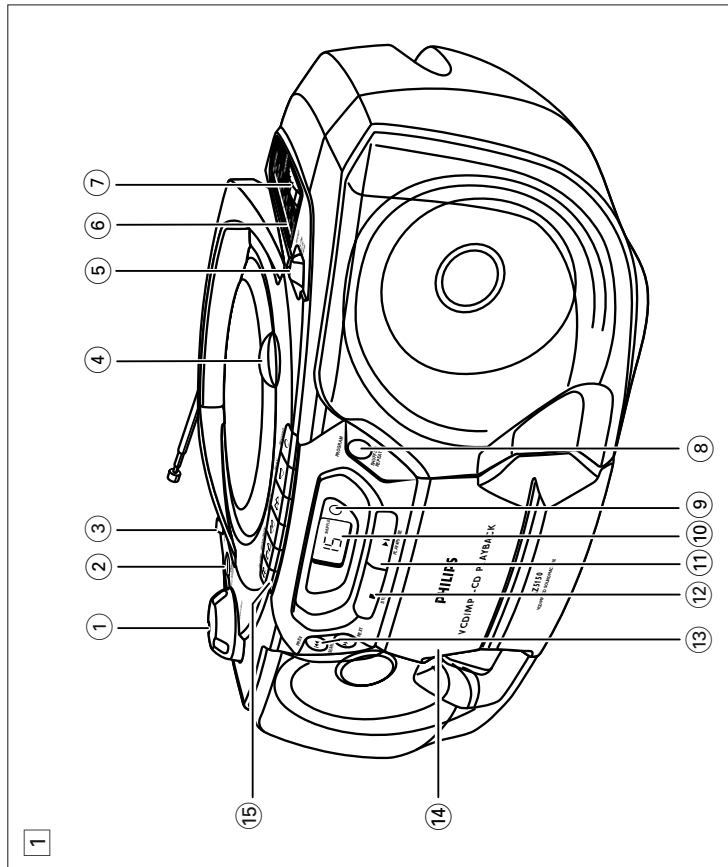

CONNECTIONS AND CONTROLS

CONTROLS

TOP AND FRONT PANEL

- 1 **VOLUME** - to adjust volume level.
- 2 **DBB (Dynamic Bass Boost)** - : for a more vivid bass response.
- 3 **Source selector** - POWER ON/OFF switch and to select source of sound source: DISC- TAPE - RADIO.
- 4 **LIFT TO OPEN** - to open the CD door.
- 5 **Band selector** - to select FM/MW wave band
- 6 **Tuning dial pointer**
- 7 **TUNING** - to tune to radio stations
- 8 **PROGRAM** - to program track numbers and to review the program.
- 9 **REMOTE SENSOR** - infrared sensor for remote control
- 10 **LCD Display** - to show the CD, VCD, MP3 functions.
- 11 **PLAY•PAUSE ►||** - To start or interrupt CD playback.
- 12 **STOP ■** - to stop playback.
- 13 **SEARCH ◀◀ or ▶▶** - to skip or search a passage or a track
- 14 **Cassette compartment**
- 15 **Cassette keys:**
PAUSE II - to interrupt recording or playback.
STOP•OPEN ■▲ - To stop the tape and to open the cassette holder.
SEARCH ◀◀ or ▶▶ - to fast wind/rewind the tape.
PLAY ◀ - to start playback.
RECORD ● - to start recording.

BACK PANEL

- 16 **Battery door** - to open the battery compartment
- 17 **COLOUR SYSTEM selector** - to switch the PAL or NTSC system.
- 18 **Telescopic aerial** - to improve radio reception
- 19 **VIDEO/AUDIO OUT** - connect to the TV or VCR VIDEO/AUDIO IN
- 20 **AC MAINS** - socket for mains lead
- 21 **PHONES** - 3.5 mm stereo headphone socket

SUPPLIED ACCESSORIES

- Remote Control 1 pc
- Mains Cord 1 pc
- Audio / Video Cable 1 pc

English

REMOTE CONTROL

REMOTE CONTROL

- 1 **PBC (PLAYBACK CONTROL)** - to switch on or off PBC mode (for VCD version 2.0 only).
- 2 **RETURN** - to return to the previous MENU level during playback (for VCD with PBC on).
- 3 **VIEW** - to scan through a VCD with 9 pictures display on TV screen. Only when PBC mode is switched off (for VCD operation only).
- 4 **OSD** - to switch on/off the on screen display on the TV screen.
- 5 **SLOW** - to watch a VCD at a slower speed (for VCD operation only).
- 6 **RESUME** - to resume playback in stop mode.
- 7 **GOTO** - to start playback at any chosen time on the disc (for CD/VCD operation only).
- 8 **PROG** for CD/VCD/MP3-CD ... to programme disc tracks.
- 9 **REPEAT** for MP3-CD only to repeat a track, an album or whole disc.
for CD/VCD to repeat a disc track or the whole disc.
- 10 **A - B** - to playback a certain scene or passage repeatedly (for CD/VCD operation only).
- 11 **ZOOM** for VCD only to zoom in or zoom out .
- 12 **SHUFFLE** - When in CD/VCD mode, press to start or stop shuffle play mode.
- 13 **NTSC/PAL** - to select the video output for NTSC or PAL system.
- 14 **R/L** - to select MONO LEFT / MONO RIGHT / STEREO.
- 15 **DIGITS 0 - 9, +10** for CD/VCD/MP3-CD ... to select a track number.
- 16 **PLAY/PAUSE ►||** for CD/VCD/MP3-CD ... to start or interrupt playback.

English

- 17 **ALBUM ◀▶** for MP3-CD only to select previous / next album
for CD/VCD to skip to the previous/next track.
- 18 **TITLE ◀◀▶▶** for MP3-CD only to select previous/next title.
for CD/VCD to search backward/forward track
- 19 **STOP ■** for CD/VCD/MP3-CD ... to stop playback or to clear a programme.

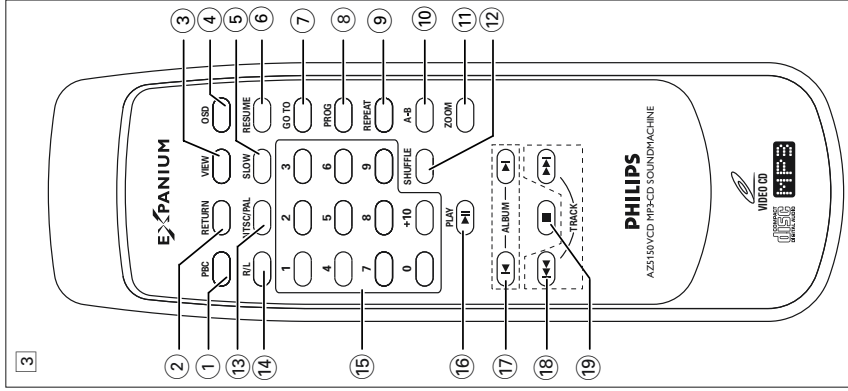

INSTRUCTIONS FOR USE

POWER SUPPLY

BATTERIES (NOT SUPPLIED)

Whenever convenient, use the mains supply if you want to conserve battery life. The battery supply will be switched off when the set is connected to the mains. Make sure you remove the plug from the set and wall outlet before inserting batteries.

Batteries

1. Open the battery compartment and insert six batteries, type **R-20 UM-1** or **D-cells**, (preferably alkaline) with the correct polarity as indicated by the "+" and "-" symbols inside the compartment.

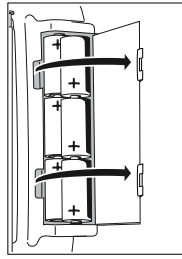

Remote control

Open the battery compartment and insert two batteries, type **AAA**, **R03** or **UM4** (preferably alkaline).

2. Replace the compartment door, making sure the batteries are firmly and correctly in place.
3. Remove the batteries if they are exhausted or if they will not be used for a long period.
 - The incorrect use of batteries can cause electrolyte leakage and will corrode the compartment or cause the batteries to burst. Therefore:
 - Do not mix battery types, e.g. alkaline with zinc carbonate.
 - When inserting new batteries, replace all at the same time.
 - Remove the batteries if the set is not to be used for a long time.

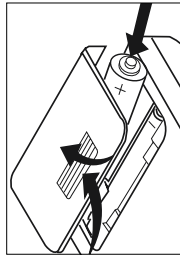

Note : The battery supply is switched off when the set is connected to the mains.

Batteries contain chemical substances, so they should be disposed of properly

MAINS

1. Check if the mains voltage as shown on the type plate (on the bottom of the set) corresponds to your local mains voltage. If it does not, consult your dealer or service organisation.
2. Connect the mains lead to the **AC~MAINS** socket and the wall socket.
 - The set is now ready for use.
3. To switch off the mains supply completely, pull the mains plug out of the wall socket.
 - Disconnect the mains lead when you change over to battery supply, or to protect the set during heavy thunderstorms.

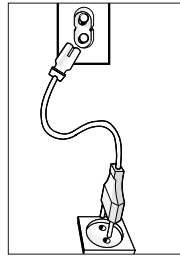

The type plate is located on the bottom of the set.

CAUTION

Use of controls or adjustments or performance of procedures other than herein may result in hazardous radiation exposure or other unsafe operation.

GENERAL OPERATION

GENERAL OPERATION

1. To switch on the set, adjust the source selector.
 - The **POWER** indicator lights up.
2. Adjust the sound using the **VOLUME** and **DBB** controls.
3. To switch off the radio, adjust the source selector to the **TAPE/POWER OFF** position, with the cassette keys released.
 - The **POWER** indicator goes out.

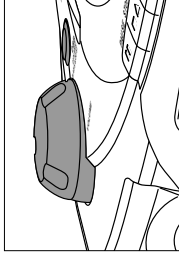

RADIO RECEPTION

1. Set the source selector to **RADIO**.
 - The **POWER** indicator lights up.
2. Adjust the sound using the **VOLUME** controls and the **DBB** switch.
3. Select the wave band using the **BAND** selector.
4. Tune to a radio station using the **TUNING** knob.
 - For FM, pull out the telescopic aerial. To improve FM-reception, incline and turn the aerial. Reduce its length if the FM-signal is too strong (very close to a transmitter).
 - For MW, the set is provided with a built-in aerial, so the telescopic aerial is not needed. Direct the aerial by turning the whole set.
5. To switch off, set the source selector to the **TAPE/POWER OFF** position (with the cassette keys released).
 - The **POWER** indicator goes out.

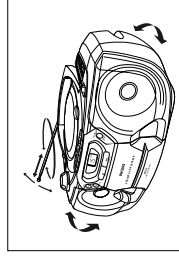
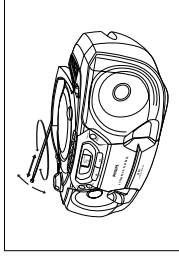

Environmental information

All unnecessary packaging material has been omitted. We have done our utmost to make the packaging easily separable into three mono materials: cardboard, polystyrene and plastic.

Your set consists of materials which can be recycled if disassembled by a specialized company. Please observe the local regulations regarding the disposal of packaging materials, exhausted batteries and old equipment.

INSTRUCTIONS FOR USE

CD/VCD/MP3-CD

IMPORTANT!

The CD part of this system also serves as a Video CD player if you connect it to your TV set.

Before viewing the Video CD, ensure that the set is switched to corresponding PAL or NTSC system of your TV set (exception Multi-system TV).

DISCS FOR PLAYBACK

This set can playback all digital audio CD, video CD, finalised digital audio CD-Recordable (CDR) discs and finalised digital audio CD-Rewritable (CDRW) discs.

**Support following MP3-CD formats:**

- ISO 9660 format - Max. 17 characters
 - Max. Track number plus Album is 256
 - Max. nested directory is 8 levels
 - The max. ALB number is 99
 - The max. MP3 programme track number is 99
 - The max. length of each track is 255 minutes 59 seconds
 - The player can play mixed mode disc:
 - a: MP3 + CDDA can only play the MP3 tracks in the first block.
 - b: VCD + CDDA full support
 - Supported VBR bit-rate
 - Supported sampling frequencies for MP3 disc : 32 kHz, 44.1 kHz, 48 kHz
 - Supported Bit-rates of MP3 disc are: 32, 64, 96, 128, 192, 256 (kbps)
- Following formats are not supported**
- The files like *.WMA, *AAC, *.DLF, *.M3U, *.PLS
 - Chinese filename
 - The non-session closed discs
 - The discs recorded under UDF format
 - Multi-session discs (can only play the first session if the session's format is the supported format).

LOADING A DISC

1. Set the source selector to Disc.
 - The POWER indicator lights up.
2. Press OPEN to open the CD door.
3. Insert a disc with the label side facing up.
4. Close the CD door.

→ The total number of tracks and the playing time of the disc appear on the display.

For MP3-CD only

→ The total album number "XXXX" will be displayed
 → On TV screen, the total ALBUM and TRACK number will display, also with the album list (max. 5 lines per page) and an arrow. The arrow indicates the current selected music.

Notes : - To ensure good system performance, wait until the disc is completely reads before proceeding.

- For MP3-CD, the disc reading time may exceed 10 seconds due to the large number of songs compiled into one disc.

CD/VCD/MP3-CD

English

PLAYING A NORMAL DISC

1. Press ▶▶ to start playback.
 - The track number and elapsed playing time of the current track appear on the display.
- To interrupt playback, press ▶▶.
- The playing time will start flashing.
- To resume playback, press ▶▶ again.
2. To stop playback, press ■.

**SELECTING A DESIRED TRACK/PASSAGE****To select a desired track**

- Press ◀◀ or ▶▶ on the set repeatedly (or on the remote control, press ◀◀ or ▶▶ or digits 0 - 9, +10) until the desired track appears on the display.
- If playback is stopped, press ▶▶ to start playback.

To search for a particular passage during playback

- Press and hold ◀◀ or ▶▶ on the set (or on the remote control, press ◀◀ or ▶▶) and release it when the desired passage is located.
 - During searching, the volume will be muted.

For MP3-CD only**To select a desired Album**

- Press and hold ◀◀ or ▶▶ on the set (or on the remote control, press ◀◀ or ▶▶) until the desired album number appear on the display.
 - "XXX" will be displayed and the album name will scroll through the display briefly.
 - On TV screen, the arrow will move forward/backward in the ALBUM menu.

To select a desired Track

- Press ◀◀ or ▶▶ on the set repeatedly (or on the remote control, press ◀◀ or ▶▶) to select a desired track from the current Album.
 - "001" will be displayed and the track name will scroll through the display briefly.
 - On TV screen, the arrow will move forward/backward in the TRACK menu.
- Use the digital keys on the remote control to select the track under current Album directly.

To select and playback another track during playback mode

1. Press ◀◀ or ▶▶ on the set (or on the remote control, press ◀◀ or ▶▶) repeatedly to select another track.
 - The current track continues playing.
 - The new selected track will show on the display screen and TV screen.
2. Press ▶▶ to start playback the new selected track.

Note : - "R" represents ALBUM is the current selected Album.

English

INSTRUCTIONS FOR USE

CD/VCD/MP3-CD

PROGRAMMING TRACKS

Programming tracks of disc is possible when playback is stopped. Up to 20 tracks can be stored in the memory in any order (except for MP-3 CD).

1. In stop mode, press **PROGM** to enter programme setting.
→ **PROG** will start flashing.
2. Press **digits 0 - 9, +10** on the remote control or **◀ / ▶** to select the desired track.
3. Press **PROGM** to store the select track.
• Repeat steps **1** to **3** to store other tracks.
4. Press **■** to end programme setting.
→ **PROG** will remain on the display.
• Press **◀** or **▶** on the set (or on the remote control, press **◀** or **▶**) in stop mode to review the programme sequence.
5. Press **▶** to play the programmed tracks.
• If you press **REPEAT** during programme playback, the current track or all programmed tracks will be played repeatedly.
→ **REPEAT/REPEAT ALL** and **PROG** will appear on the display.
6. Press **■** in stop mode to clear the programme.
→ **PROG** will disappear from the display

Notes :- "P" represents **PROGRAMME** and "T" represents **TRACK**, "XXX" is the current selected Programme or Track number.
- The programming is automatically cleared as soon as the CD compartment is opened.
- The function of programme setting is disable in **PLAY/PAUSE** mode.
- Programme cannot be used for VCDs when **PBC** is switched on. Switch off **PBC** before storing tracks from such a VCD.

For MP3-CD only

1. In stop mode, press **PROGM**.
→ **PROG** will start flashing and " 0 1 " will be displayed.
→ On TV screen, "PXX-AXX TXX?" and "PROGRAM" will be displayed.
2. Press and hold **◀ / ▶** to select the desired **ALBUM** and press **◀ / ▶** repeatedly (or **digits 0 - 9, +10** on the remote control) to select the desired **TRACK** for programming.
3. Press **PROGM** to store the select track.
→ " XXX " will show on the display screen and " PXX DJK " on TV screen.
→ **PROG** will remain on the display.
• Repeat steps **1** to **3** to store other desired album and track.
• Press **◀** or **▶** in stop mode can review the programme sequence.
→ " PXX PXX TXXX " will show on TV screen.
- Press **◀ / ▶** in stop mode to show the programme information.
→ The Album's number and Track's number will show on the display screen.
4. Press **▶** to start programme playback. You can press **◀ / ▶** to select the programmed track to play.
5. Press **■** once stop programme playback or **twice** to clear the programme.

English

CD/VCD/MP3-CD

SHUFFLE

You can play all the tracks in random order.

1. During playing, pause or stop mode, press **SHUFFLE** to enable **SHUFFLE** play mode.
→ **SHUFFLE** will appear on the display.
2. To exit shuffle mode, press **SHUFFLE** again or **■**.
→ **SHUFFLE** will disappear from the display.

Note :- If the Shuffle function enabled, and the Repeat function is set on, will disable the Shuffle play mode.

REPEAT

You can play the current track or the whole disc repeatedly.

1. During CD Playing or Pause mode, press **REPEAT** on the set or remote control.
→ **REPEAT** - to repeat the current track.
→ **REPEAT ALL** - to repeat the whole disc.
- For MP3-CD, you are able to select **REPEAT**, **REPEAT ALL** or **REPEAT ALB** mode.
→ **REPEAT ALB** - to repeat the current album.
- The current track or whole disc will now be played repeatedly until you press **■**.
2. To exit the repeat mode, press **REPEAT** until the **REPEAT/REPEAT ALL/REPEAT ALB** disappears from the display.

Notes :- If the Repeat function is enable, and the Shuffle function is set on, will disable all the Repeat play modes.
- If the Repeat function is enable, and the Stop button is pressed, will disable all the Repeat play modes.
- In programme mode, you can only select Repeat or Repeat All function.

VIDEO CD

Adjusting the TV System

Before viewing the Video CD, ensure that the set is switched to corresponding PAL or NTSC system of your TV set (exception Multi - system TV).

1. Set the colour system selector to the **PAL/A** or **NTSC/B** position as default setting. After TV system is selected, the set will automatically switch to the default setting every time the VCD source is selected.
2. On the remote control, press **NTSC/PAL** to switch between **NTSC** and **PAL** TV system.

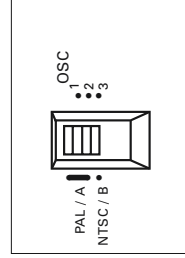

OSD - On Screen Display

If you insert VCD/CD, your TV screen will serve as an additional display for messages (e.g. **PLAY**, **STOP**), and information stored on the VCD/CD.

- Press **OSD** on the remote control to select viewing various information.
→ The current track and current /remaining time in the track/disc appear on the display.

VIDEO CD

Playing a Video CD with PBC

VCD with PBC (Playback Control) will be indicated on the display of the set and on your TV screen as soon as they are inserted. PBC is a predefined play sequence stored on the VCD.

1. Switch on the TV, insert a VCD with PBC.
2. Menu appears on the TV screen.

If the menu consists of a list of titles, you can select a sequence directly

1. Press **digits 0 - 9, +10** on the remote control to select your choice.
→ The VCD starts playing of the selected sequence automatically.
2. Press **RETURN** on the remote control to go back to the previous menu.

Note :- If a menu consists of more than one page, press **◀** / **▶** to go through the pages.

Switching off PBC

- In stop mode, press **PBC**.
→ On TV screen, "PBC OFF" will be displayed.

Notes :- Programme mode is not available whenever PBC mode is switched on.

- The menu structure depends on the programme stored on the VCD. Please refer to the information supplied with the disc.

Pause

1. During playback, press **▶** to have a still picture on the TV screen.
→ The sound will be muted.
→ On TV screen, "PAUSE" will be displayed.
2. Press **▶** again to continue playback.

Goto

1. Press **GOTO** on the remote control.
---:-- will be displayed.
On TV screen, "GOTO ---:" will be displayed.

2. Press **digits 0 - 9, +10** on the remote control to key in the disc time which you want the disc to begin playback.

Note :- The disc time entered should not be greater than the total disc time.

Slow

1. Press **SLOW** on the remote control to watch a VCD at a slower speed. There are 3 types of slow modes to select.
→ The sound will be muted.
→ On TV screen, "SLOW 1/2", "SLOW 1/4" or "SLOW 1/8" will be displayed.
2. To resume playback at normal speed, press **SLOW** repeatedly until "PLAY" appears on the TV screen or press **▶**.

VIDEO CD

A-B repeat

This feature is also applicable to audio CD (except for MP3-CD). To Play a certain scene or passage of the disc repeatedly.

1. Press **A-B** on the remote control during playback to mark the start point of the chosen scene or passage.
→ **A** → will appear on the display.
2. Press **A-B** again to mark the end of the chosen scene or passage.
→ **A-B** will appear on the display.
→ The selected scene or passage will start playing repeatedly.
3. Press **A-B** once more to return to normal playback.
→ **A-B** will disappear from the display.

Notes :- You can also cancel A-B repeat by pressing **◀** or **▶**.

- A-B repeat marking can cross from one track to another. But for VCD 2.0, you can only able to set the A-B repeat marking within the same track.

Resume

- In stop mode, press **RESUME** on the remote control to start playback again from where you have stopped.

Note :- Resume will not be available if you have changed the disc, opened the disc tray or disconnected the system the power supply.

View

This feature allows you to scan through a VCD for a quick review. PBC mode must be switched off.

1. Press **VIEW** on the remote control.
→ On TV screen, 9 pictures will be displayed. To view the previous/next page, press **◀** or **▶**.
→ The first 20 seconds of each track will be played.
2. To exit review mode, press **digits 0 - 9, +10** to playback the desired track or **▶** to play the current selected track.

Note :- If the disc is AVCD disc and there're no video tracks on the same viewed page, cannot use the direct digital key to play the track.

Return

- Press **RETURN** on the remote control to return to the previous VCD disc MENU level. It is functional only for Video CD when PBC is switched on.

R/L

You can use it to select the different audio modes.

- Press **R/L** on the remote control repeatedly to select the following modes:
L → **R** → **L** → **R**
- Channel Left/Right - Select the language on a bilingual VCD.

INSTRUCTIONS FOR USE

CASSETTE RECORDER

CASSETTE PLAYBACK

1. Set the source selector to **TAPE/POWER OFF**.
2. Press **STOP•OPEN** \blacksquare \blacktriangle to open the cassette holder.
3. Insert a recorded cassette.
4. Press **PLAY** \blacktriangleleft and playback will start.
 - The POWER indicator lights up.
5. Adjust the sound using the **VOLUME** and **DBB** controls.
6. For brief interruptions, press **PAUSE II**. Press **PAUSE II** again to resume playback.
7. By pressing \blacktriangleleft or \blacktriangleright , fast winding of the tape is possible in both directions.
8. To stop playback, press **STOP•OPEN** \blacksquare \blacktriangle .
 - The keys are automatically released at the end of the tape.
9. Set the source selector to **TAPE/POWER OFF** position (with the cassette keys are released) to switch off the set.
 - The POWER indicator goes out.

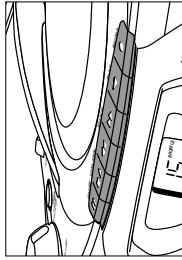

English

CASSETTE RECORDER

RECORDING FROM THE RADIO

1. Set the source selector to **TUNER**.
 - The POWER indicator lights up.
2. Tune to the desired radio station using the TUNING knob.
3. Press **STOP•OPEN** \blacksquare \blacktriangle to open the cassette holder.
4. Insert a blank tape.
5. Press **RECORD** \bullet to start recording.
6. For brief interruptions, press **PAUSE II**. To resume recording, press **PAUSE II** again.
7. To stop recording, press **STOP•OPEN** \blacksquare \blacktriangle .



SYNCHRO START CD RECORDING

1. Set the source selector to **CD**.
 - The POWER indicator lights up.
 2. Insert a CD and if desired, programme track numbers.
 3. Press **STOP•OPEN** \blacksquare \blacktriangle to open the cassette holder.
 4. Insert a blank cassette.
 5. Press **RECORD** \bullet to start recording.
 - Playing of the CD programme starts automatically from the beginning of the programme. It is not necessary to start the CD player separately.
 6. For brief interruptions, press **PAUSE II**. To resume recording, press **PAUSE II** again.
 7. To stop recording press **STOP•OPEN** \blacksquare \blacktriangle .
- To select and record a particular passage within a track**
1. Press **SEARCH** \blacktriangleleft or \blacktriangleright to select a passage.
 2. Put the CD player in **PAUSE II** position at the selected passage.
 - Recording will start from this exact point when you press **RECORD** \bullet .

CASSETTE RECORDING

General information on cassette recording

- Recording is permissible insofar as copyright or other rights of third parties are not infringed.
- This deck is not suitable for recording on CHROME (IEC II) or METAL (IEC IV) type cassettes. For recording you should use NORMAL type cassettes (IEC I) on which the tabs have not been broken.
- Check and tighten slack tape before use with a pencil, to avoid jamming the deck mechanism.
- The recording level is set automatically. Altering the VOLUME and DBB controls will not affect the recording in progress.
- No recording will take place during the 7 seconds, when the leader tape passes the recorder heads.
- To prevent the accidental erasure of a recording, keep the cassette side to be safeguarded in front of you and break out the left tab. Recording on this side is no longer possible.

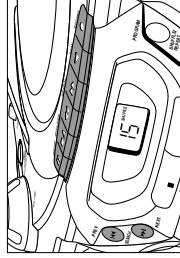
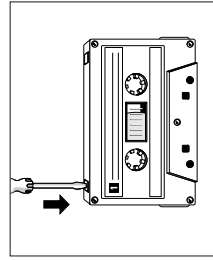

PRECAUTIONS & GENERAL MAINTENANCE

- Place the set on a hard, flat surface so that the system does not tilt.
- Do not expose the set, CDs, batteries or cassettes to humidity, rain, sand or excessive heat caused by heating equipment or direct sunlight.
- Always shut the CD door to keep the CD compartment dust-free. To clean, dust the compartment with a soft dry cloth.
- Do not cover the set. Adequate ventilation with a minimum gap of 15 cms between the ventilation holes and surrounding surfaces is necessary to prevent heat build-up.
- The mechanical parts of the set contain self-lubricating bearings and must not be oiled or lubricated.
- To clean the set, use a soft, slightly dampened chamois leather. Do not use any cleaning agents containing alcohol, ammonia, benzene or abrasives as these may harm the housing.

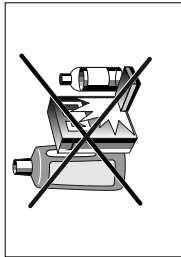
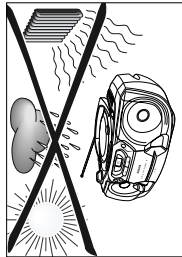

CD PLAYER AND CD HANDLING

- The lens of the CD player should *never be touched*.
- Sudden changes in the surrounding temperature can cause condensation to form and the lens of your CD player to cloud over. Playing a CD is then not possible. Do not attempt to clean the lens but leave the set in a warm environment until the moisture evaporates.
- Use only Digital Audio CDs.
- To take a CD out of its box, press the centre spindle while lifting the CD.
- Always pick up the CD by the edge and replace the CD back in its box after use to avoid scratching and dust.
- To clean the CD, wipe in a straight line from the centre towards the edge using a soft, lint-free cloth. Do not use cleaning agents as they may damage the disc.
- *Never write* on a CD or attach stickers to it.

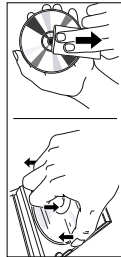
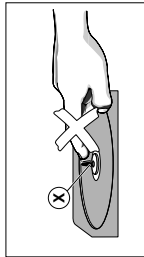

TAPE DECK MAINTENANCE

- To ensure a good recording and playback of the tape deck, clean parts (A), (B) and (C) show in the diagram below, after approx. 50 hours of operation, or on average once a month. Use a cotton bud slightly moistened with alcohol or a special head cleaning fluid to clean the deck.
- Open the cassette holder by pressing STOP ◀ OPEN ▶▲.
 - Press PLAY ▶ and clean the rubber pressure rollers (C).
 - Press PAUSE ⏸ and clean the magnetic heads (A) and also the capstans (B).
 - After cleaning, press STOP ◀ OPEN ▶▲.

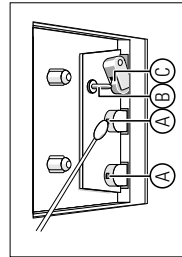

Cleaning of the heads can also be done by playing a cleaning cassette through once.

If a fault occurs, first check the points listed below before taking the set for repair. If you are unable to remedy a problem by following these hints, consult your Dealer or service centre.

WARNING: Do not open the set as there is a risk of electric shock. Under no circumstances should you try to repair the set yourself, as this will invalidate the guarantee.

English

Problem	Solution
CD/VCD OPERATION "NO DISC" is displayed	<ul style="list-style-type: none"> – Insert a disc. – Check if the disc is inserted upside down. – Wait until the moisture condensation at the lens has cleared. – Replace or clean the disc, see "Maintenance" – Use a readable disc or correct recorded format MP3-CD.
No picture on TV screen	<ul style="list-style-type: none"> – Connect the cable between the system and TV.
No colour on TV	<ul style="list-style-type: none"> – Change the system to the respective PAL or NTSC setting.
RADIO RECEPTION Radio reception is poor	<ul style="list-style-type: none"> – If the signal is too weak, adjust the antenna for better reception. – Increase the distance between the Receiver and your TV or VCR.
TAPE OPERATION/RECORDING Recording or playback cannot be made	<ul style="list-style-type: none"> – Clean deck parts, see "Maintenance". – Use only NORMAL (IEC I) tape. – Apply a piece of adhesive tape over the missing tab space.
GENERAL The system does not react when buttons are pressed	<ul style="list-style-type: none"> – Remove and reconnect the AC power plug and switch on the system again.
Sound cannot be heard or is of poor quality	<ul style="list-style-type: none"> – Adjust the volume. – Make sure the MP3-CD was recorded within 96-256 kbps bit rate with sampling frequencies at 48 kHz, 32 kHz.
The remote control does not function and properly	<ul style="list-style-type: none"> – Reduce the distance between the remote control and the system. – Insert the batteries with their polarities (+/- signs) aligned as indicated. – Replace the batteries. – Point the remote control in the direction of the system's IR sensor.

DISASSEMBLY DIAGRAM

- A. REMOVE BACK CABINET ASSEMBLY
- REMOVE SCREWS A1(3x35) 3PCS
 - REMOVE SCREWS A2(3x20) 2PCS
 - REMOVE SCREWS A3(3x12) 2PCS
 - REMOVE BACK CABINET



- B. REMOVE HANDLE
- PRESS DOWN THE STOPPER AND PULL THE HANDLE OUT
 - REMOVE HANDLE



- C. REMOVE TOP CABINET ASSEMBLY
- REMOVE SCREWS C4(3x15) 2PCS
 - REMOVE SCREWS C5(3x10) 1PC
 - REMOVE TOP CABINET



ABBREVIATIONS AND PIN-DESCRIPTION OF ICS

SERVO PROCESSOR SAA7324H

SYMBOL	PIN	DESCRIPTION
HFREF	1	comparator common mode input
HFIN	2	comparator signal input
ISLICE	3	current feedback output from data slicer
V _{SSA1}	4 ⁽¹⁾	analog ground 1
V _{DDA1}	5 ⁽¹⁾	analog supply voltage 1
I _{ref}	6	reference current output pin
V _{RIN}	7	reference voltage for servo ADC' s
D1	8	unipolar current input (central diode signal input)
D2	9	unipolar current input (central diode signal input)
D3	10	unipolar current input (central diode signal input)
D4	11	unipolar current input (central diode signal input)
R1	12	unipolar current input (satellite diode signal input)
R2	13	unipolar current input (satellite diode signal input)
V _{SSA2}	14 ⁽¹⁾	analog ground 2
CROUT	15	crystal/resonator output
CRIN	16	crystal/resonator input
V _{DDA2}	17 ⁽¹⁾	analog supply voltage 2
LN	18	DAC left channel differential output - negative
LP	19	DAC left channel differential output - positive
V _{neg}	20	DAC negative reference input
V _{pos}	21	DAC positive reference input
RN	22	DAC right channel differential output - negative
RP	23	DAC right channel differential output - positive
SELPLL	24	selects whether internal clock multiplier PLL is used
TEST1	25	test control input 1; this pin should be tied LOW
CL16	26	16.9344 MHz system clock output
DATA	27	serial d4(1)ata output (3-state)
WCLK	28	word clock output (3-state)
SCLK	29	serial bit clock output (3-state)
EF	30	C2 error flag output (3-state)
TEST2	31	test control input 2; this pin should be tied LOW
KILL	32	kill output (programmable; open-drain)
V _{SSD1}	33 ⁽¹⁾	digital ground 2
V2/V3	34	versatile I/O: input versatile pin 2 or output versatile pin 3 (open-drain)
WCLI	35	word clock iutput (for data loopback to DAC)
SDI	36	serial data input (for data loopback to DAC)
SCLI	37	serial bit clock input (for data loopback to DAC)
RESET	38	power-on reset input (active LOW)
SDA	39	microcontroller interface data I/O line (open-drain output)
SCL	40	microcontroller interface clock line input

ABBREVIATIONS AND PIN-DESCRIPTION OF ICS

SERVO PROCESSOR SAA7324H

SYMBOL	PIN	DESCRIPTION
RAB	41	microcontroller interface R/W and load control line input (4-wire bus mode)
SILD	42	microcontroller interface R/W and load control line input (4-wire bus mode)
STATUS	43	servo interrupt request line/decoder status register output (open-drain)
TEST3	44	test control input 3; this pin should be tied LOW
RCK	45	subcode clock input
SUB	46	P-to-W subcode bits output (3-state)
SFSY	47	subcode frame sync output (3-state)
SBSY	48	subcode block sync output (3-state)
CL11/4	49	11.2896 MHz or 4.2336 MHz (for microcontroller) clock output
V _{SSD2}	50 ⁽¹⁾	digital ground 3
DOBM	51	bi-phase mark output (externally buffered; 3-state)
V _{DD1(P)}	52 ⁽¹⁾	digital supply voltage 2 for periphery
CFLG	53	correction flag output (open-drain)
RA	54	radial actuator output
FO	55	focus actuator output
SL	56	sledge control output
V _{DD2(C)}	57 ⁽¹⁾	digital supply voltage 3 for core
V _{SSD3}	58 ⁽¹⁾	digital ground 4
MOTO1	59	motor output 1; versatile (3-state)
MOTO2	60	motor output 2; versatile (3-state)
V4	61	versatile output pin 4
V5	62	versatile output pin 5
V1	63	versatile intput pin 1
LDON	64	laser drive on output (open-drain)

Note : All supply pins must be connected to the same external power supply voltage.

BLOCK DIAGRAM OF INTEGRATED CIRCUIT

SERVO PROCESSOR SAA7324

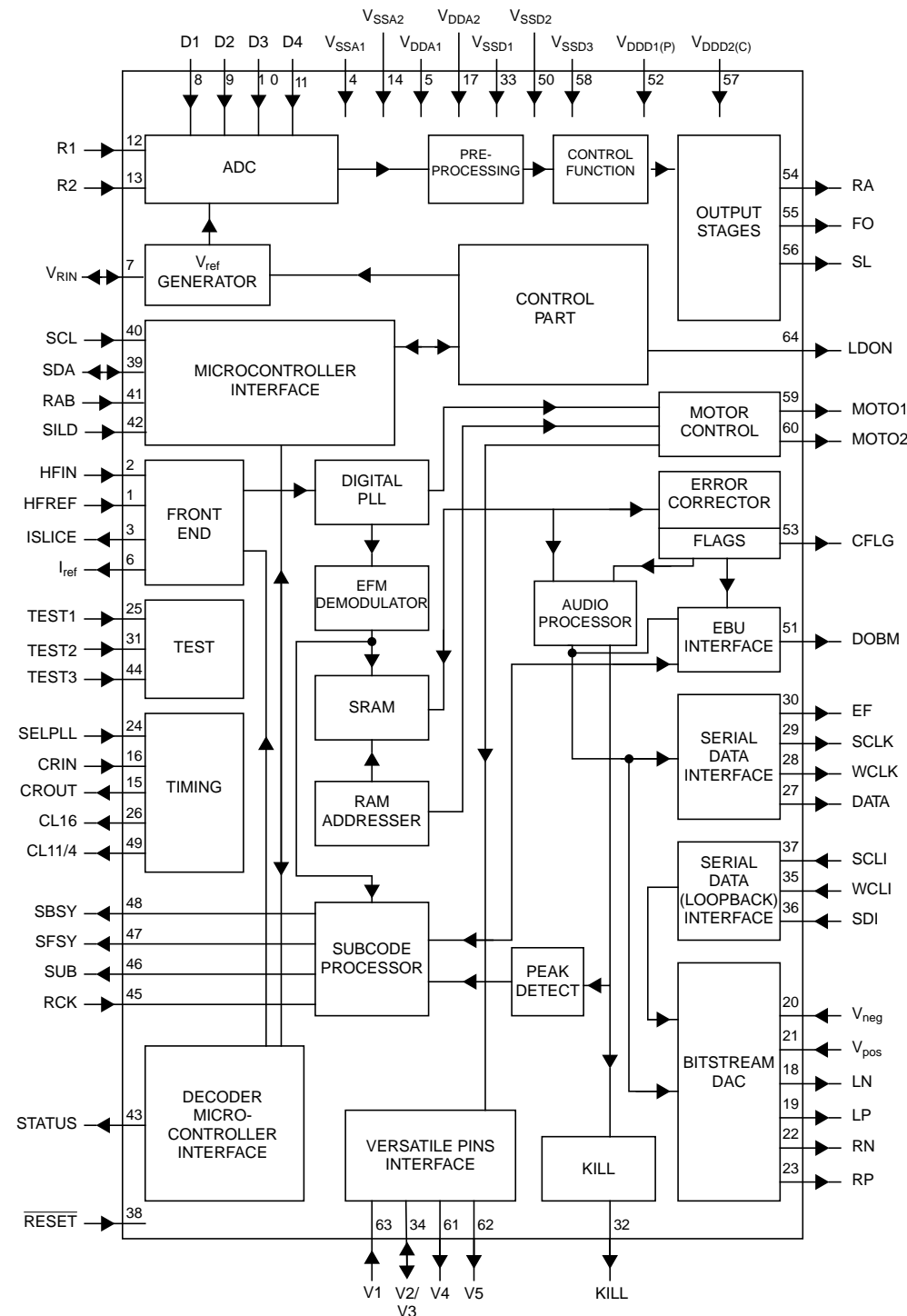

BLOCK DIAGRAM OF INTEGRATED CIRCUIT

VIDEO DECODER LS187C

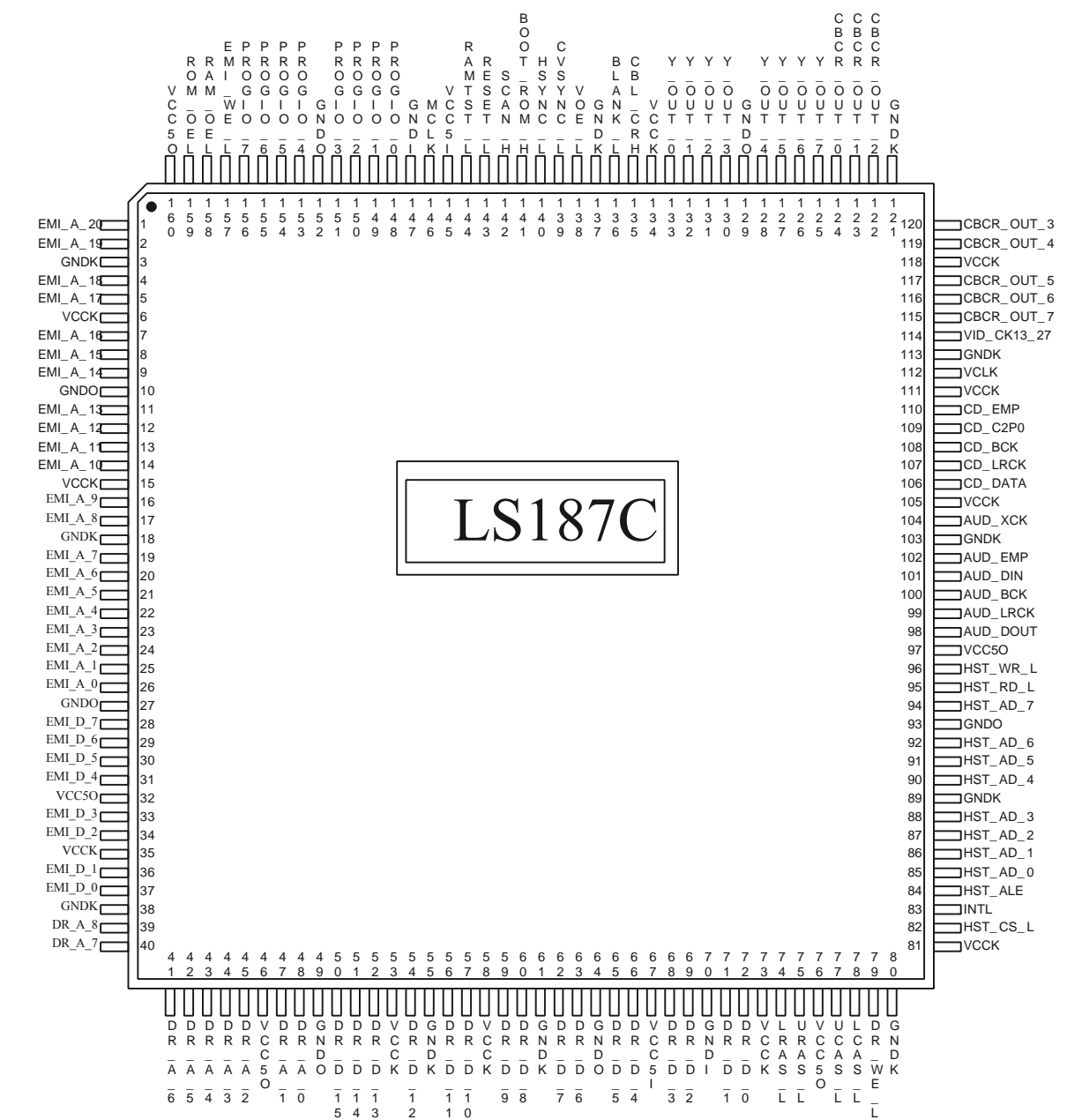

VCCK = 3.3V
 VCC51 = VCC5K = 5V
 GNDK = GNDI = GND0 = GND

BLOCK DIAGRAM OF INTEGRATED CIRCUIT

CS8552

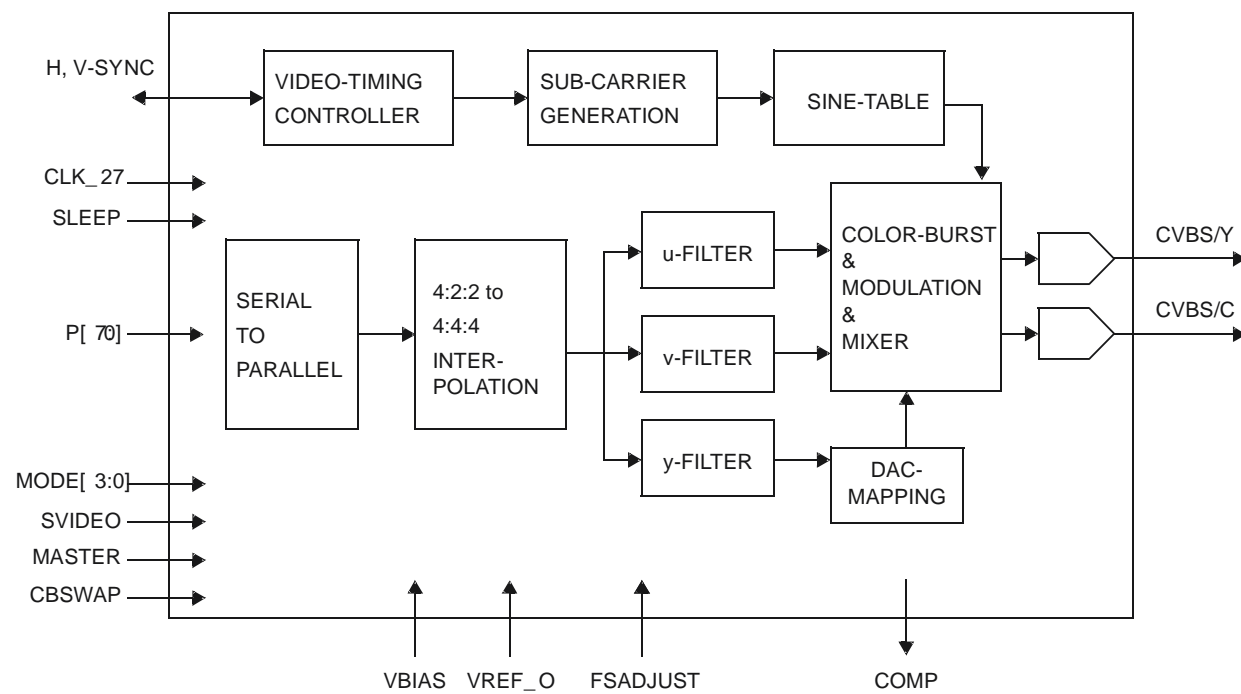

PINS DESCRIPTION OF INTEGRATED CIRCUIT

CS8552

Name	I/O	Pin	Description
CLKI	I	29	Pixel clock, 27MHz, twice the Y sample rate
VSYNC	I/O	32	Vertical sync, output in master mode or input in slave mode, is synchronized by CLK.
HSYNC	I/O	1	Horizontal sync, output in master mode or input in slave mode, is synchronized by CLK too.
P[7:0]	I	28-21	YCbCr pixel inputs (TTL compatible). Also, synchronized by CLK with respect to the incoming HSYNC timing, the higher index corresponds to a greater significance.
MD[3:0]	I	17-20	Configuration inputs
MASTER	I	16	in 0: slave mode, h and v sync are inputs. 1: master mode, h and v sync are outputs.
CBSWAP	I	15	0: normal Cr, Cb sequence. 1: swaps Cr, Cb sequence
SVIDEO	I	14	0: composite output same signal on both Y, C channels, 1: s-video output, Y, C channels.
SLEEP	I	13	1: power down, reset 0: normal operation
FSADJUST	I	5	Full scale adjust control pin. A resistor is connected to GND. Used to control the full-scale output current on analog outputs.
COMP	I	6	Compensation pin. A 0.1µF capacitor is used to bypass this pin to VCC.
VREFO	I	8	Voltage reference output, typically 1.2V, may be used to connect to VREFI input.
VREFI/VRDAC	I	9	Voltage reference input, typically 1.235V. A 0.11µF capacitor must be used to decouple this input to GND. DAC current switch reference input, connect to VREFO output.
VBIAS	O	10	DAC bias voltage, 0.7 v less than COMP signal
CVBS/C	O	11	Composite output or chrominance
CVBS/Y	O	4	Composite output or luminance (with blanking and sync)
VAA		7	Analog power
VDD		31	Digital power
GND		30	Digital ground
AGND		3, 12	Analog ground
NC		2	No connection

BLOCK DIAGRAM OF INTEGRATED CIRCUIT

IS41C16256

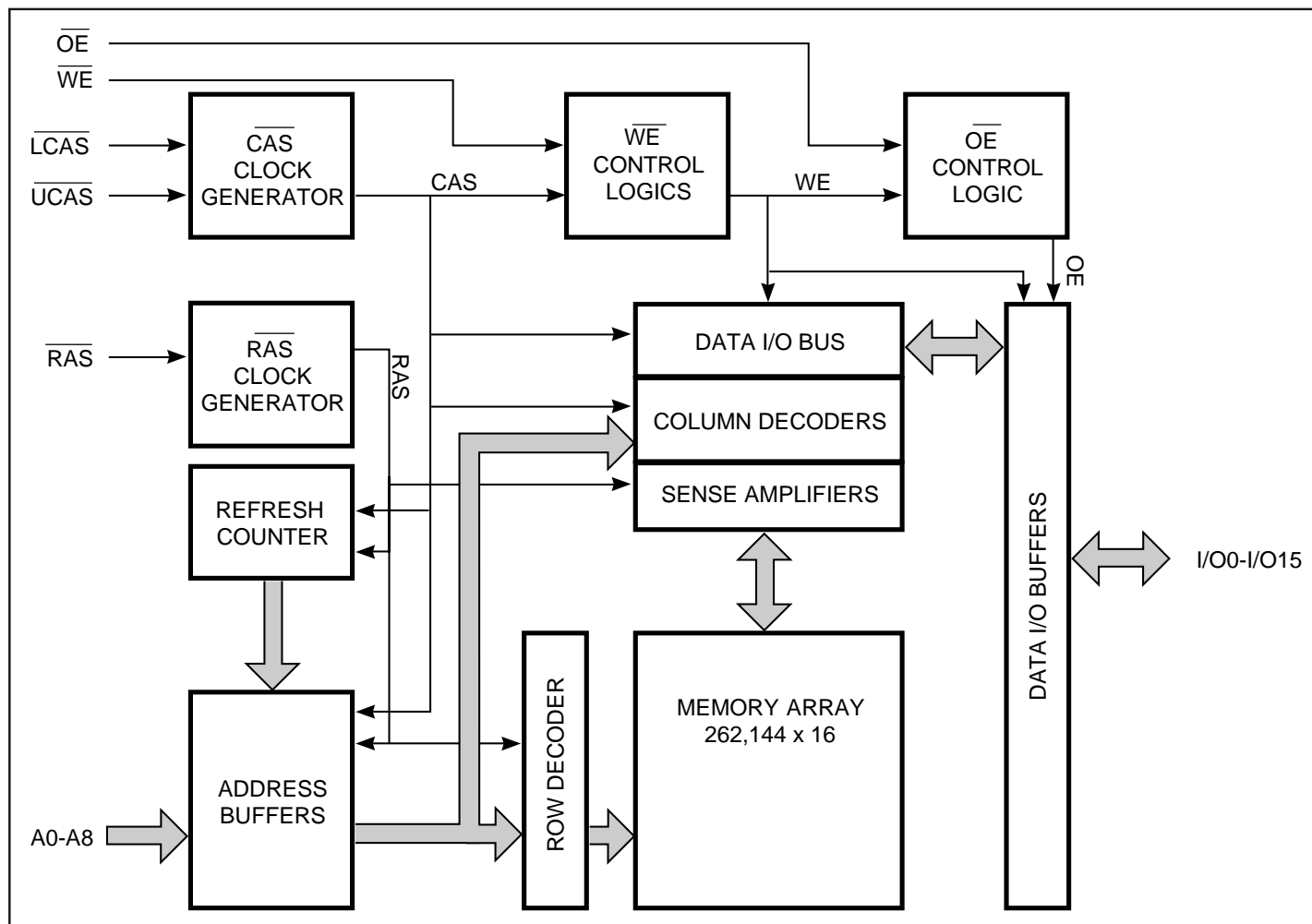

IS41C16256

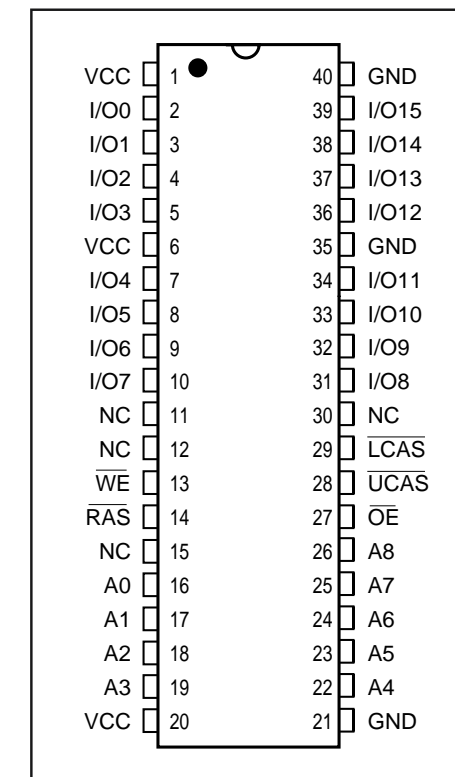

W27C 020

BLOCK DIAGRAM

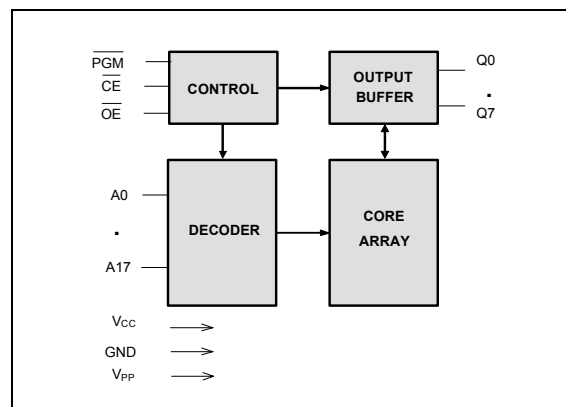

PIN DESCRIPTION

SYMBOL	DESCRIPTION
A0-A17	Address Inputs
Q0-Q7	Data Inputs/Outputs
\overline{CE}	Chip Enable
\overline{OE}	Output Enable
\overline{PGM}	Program Enable
V_{PP}	Program/Erase Supply Voltage
V_{CC}	Power Supply
GND	Ground

BA3313L

BLOCK DIAGRAM

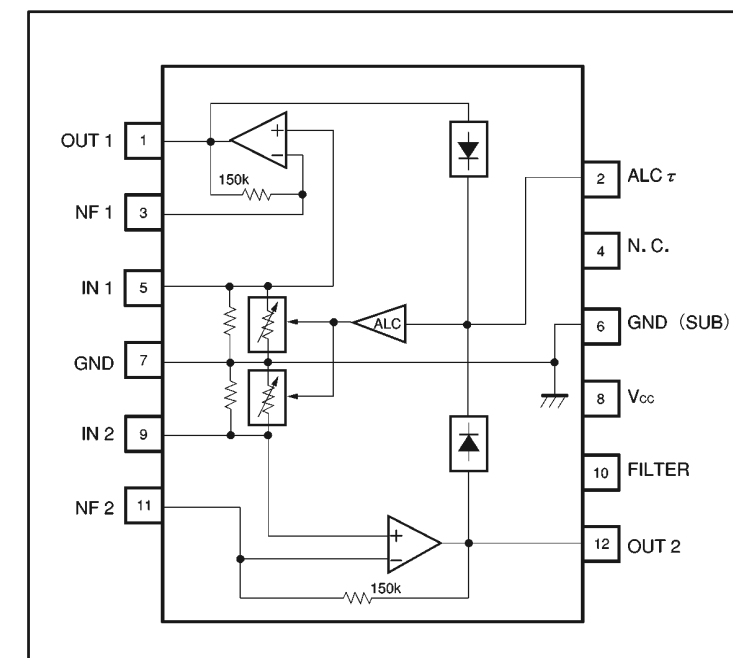

BLOCK DIAGRAM

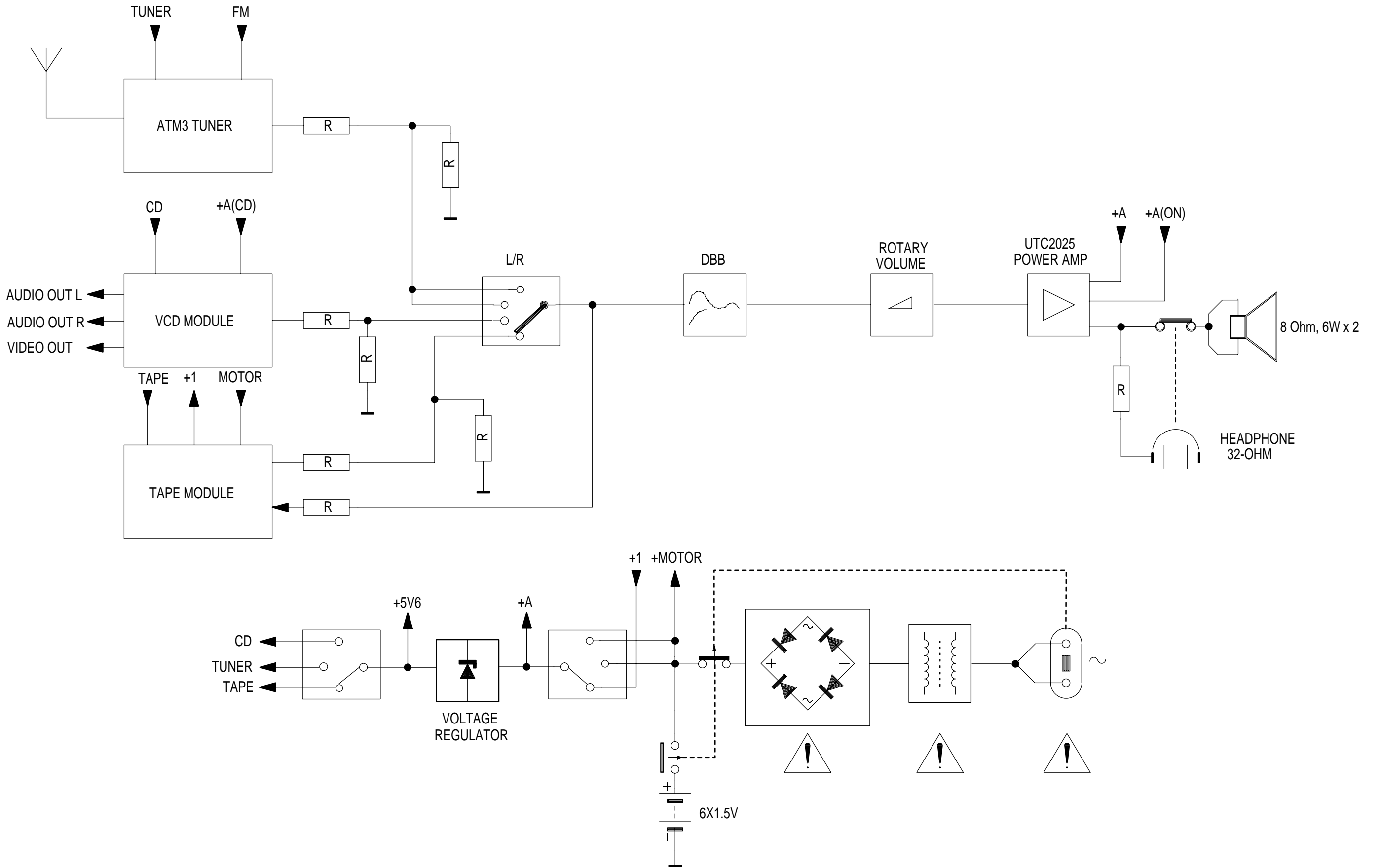

WIRING DIAGRAM

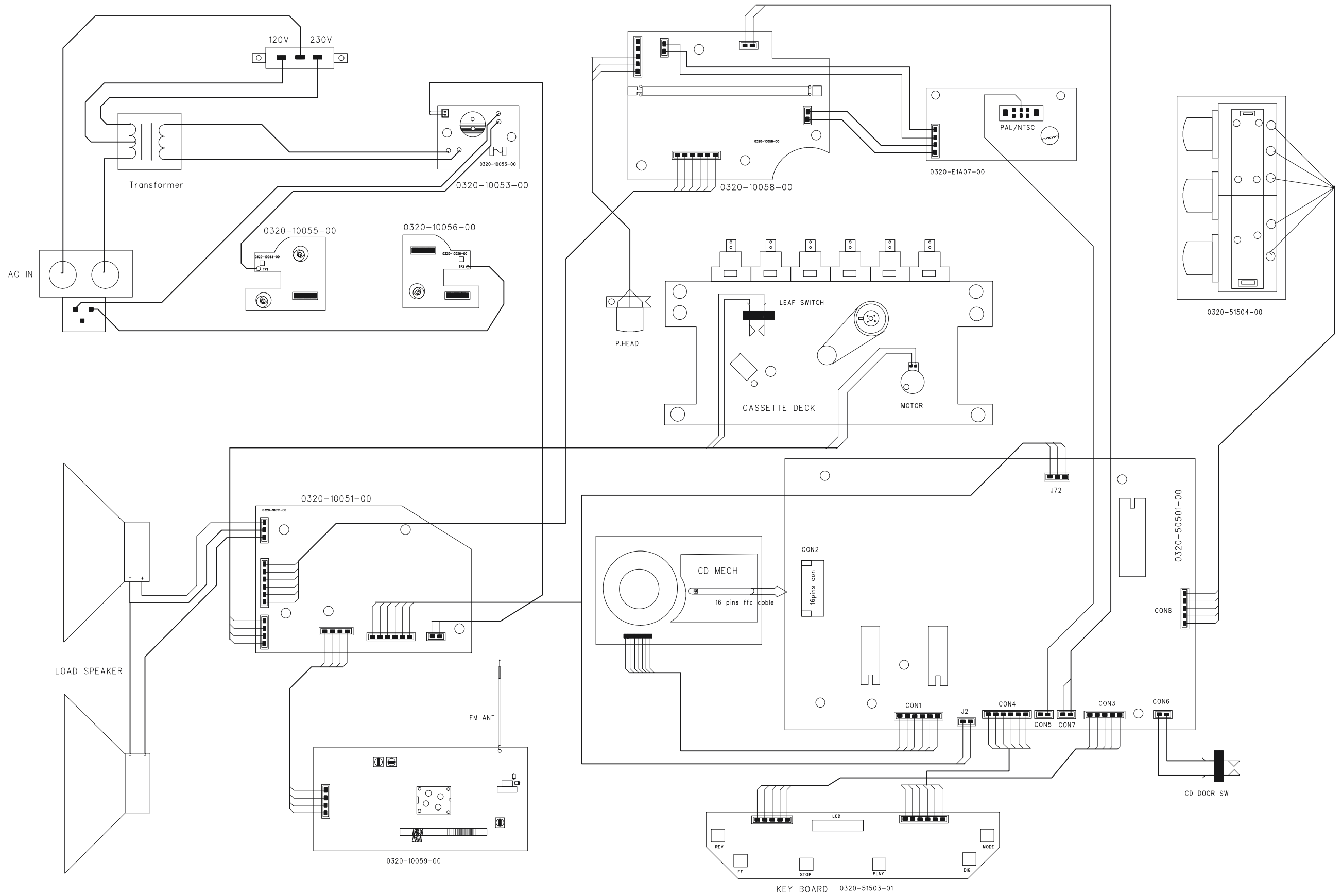

TUNER BOARD - CIRCUIT DIAGRAM

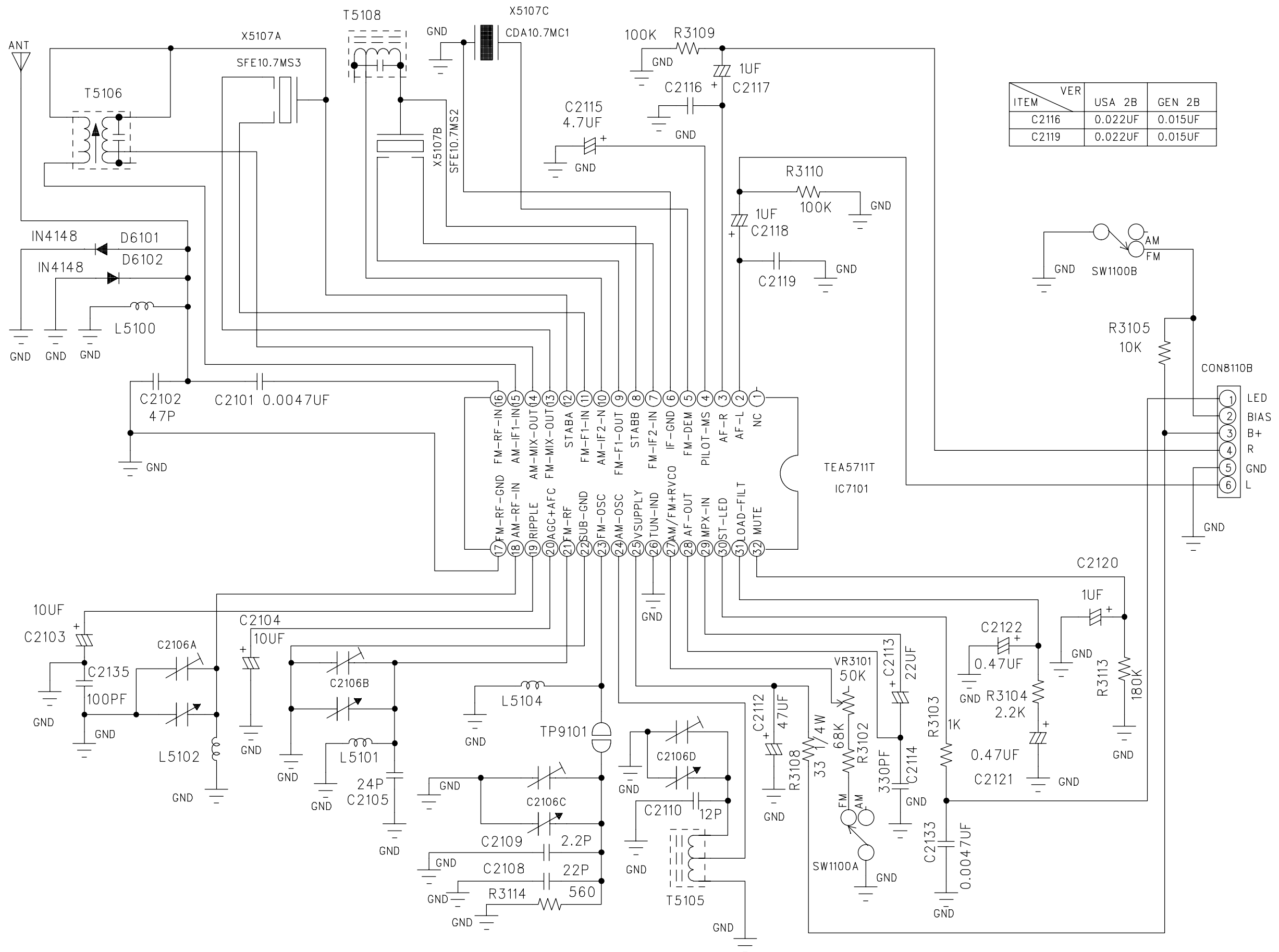

TUNER BOARD - LAYOUT DIAGRAM

1102 B 1	2106 A 2	2113 B 4	2119 B 4	3101 A 4	3109 B 4	5104 A 3	5108 B 4	9108 B 2	9211 B 2
2101 B 3	2107 A 3	2114 B 4	2120 A 4	3102 A 3	3110 B 4	5105 A 2	6101 B 1	9109 B 3	
2102 B 3	2108 A 3	2115 B 4	2121 A 4	3103 A 4	3113 A 4	5106 B 3	6102 B 1	9113 A 2	
2103 B 2	2109 A 3	2116 B 4	2122 A 4	3104 A 4	3114 A 3	5107a B 3	7101 B 4	9120 B 4	
2104 B 2	2110 A 2	2117 B 4	2133 A 4	3105 A 4	5101 B 3	5107b B 4	8110 A 4	9121 B 4	
2105 B 2	2112 A 4	2118 B 4	2135 B 2	3108 A 4	5102 A 2	5107c B 4	9101 A 3	9122 A 3	

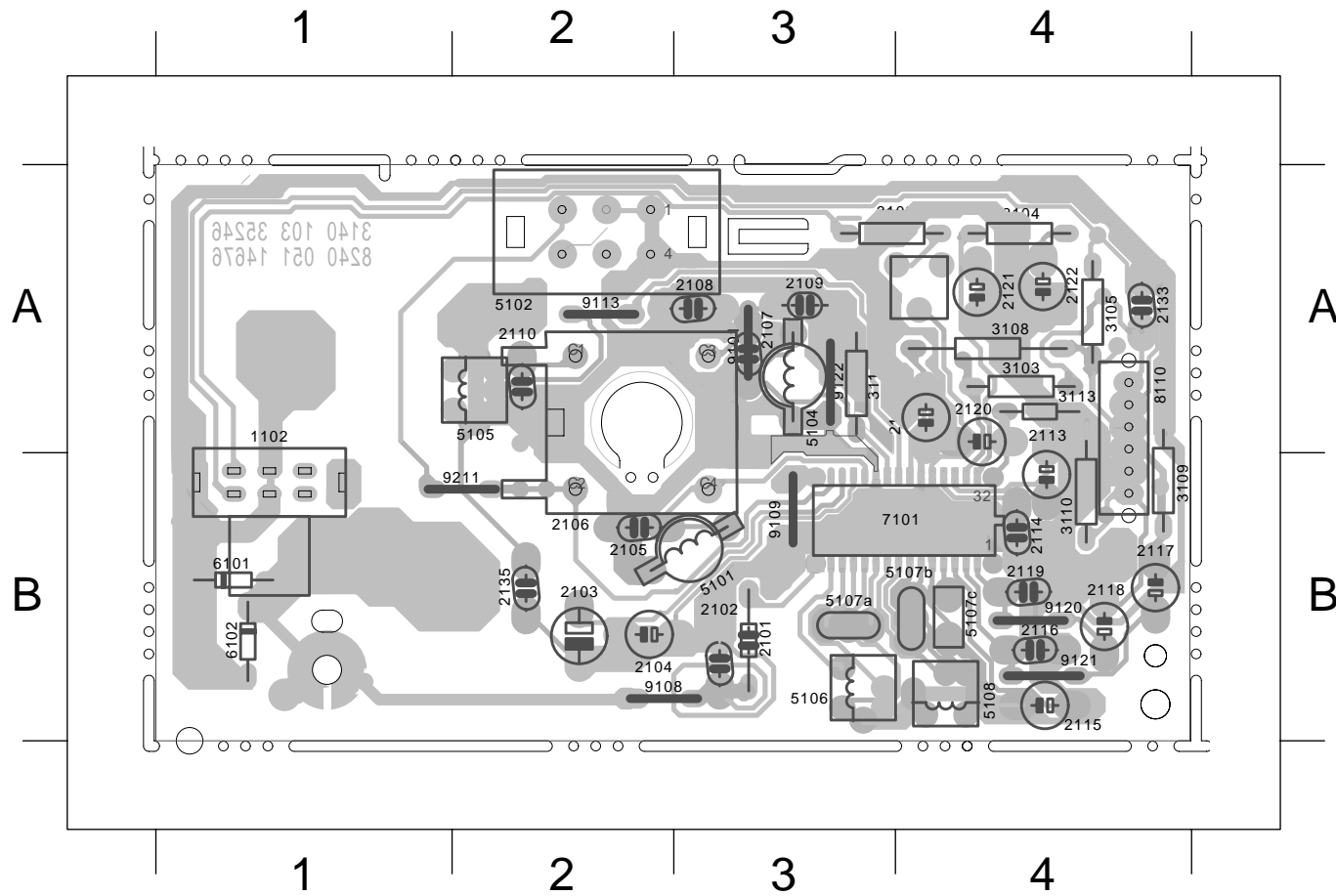

TUNER ADJUSTMENT TABLE (ATM3 FM/AM - versions with AM-frame aerial)

Waverange	Input Frequency	Input	Set tuned to	Adj ust	Measure on	Scope / Counter
OSCILLATOR						
FM 87,5 - 108 MHz	87,35 MHz	A $\Delta f = \pm 500\text{kHz}$ $V_{RF} = 100\mu\text{V}$	lower band end	5104	1 or 2	
	108,25 MHz		upper band end	2106 C1		
MW 525 - 1607 kHz (530 - 1710 kHz) ¹⁾	512 kHz (520 kHz)	C $\Delta f = \pm 30\text{kHz}$ $V_{RF} = 100\mu\text{V}$	lower band end	5105	1 or 2	
	1635 kHz (1730 kHz)		upper band end	2106 C3		
FM - RF						
FM 87,5 - 108 MHz	87,5 MHz	A $\Delta f = \pm 500\text{kHz}$ $V_{RF} = 10\mu\text{V}$	87,5 MHz	5101	1 or 2	
	108 MHz		108 MHz	2106 C2		
VCO						
FM	98 MHz	A continuous wave $V_{RF} = 1\text{ mV}$	98 MHz	3101	3 	152 ±1 kHz
AM - IF						
AM	468 kHz connect pin 24 of IC 7101 (AM Osc) with short wire to ground	C $\Delta f = \pm 15\text{kHz}$ $V_{RF} = 10\text{mV}$		5106	1 or 2	
			see remark 2)	5108		
AM - RF						
MW	560 kHz	B 	560 kHz	5111	1 or 2	
	1500 kHz		1500 kHz	2106 C4		

↑ repeat
¹⁾ for USA /17
²⁾ RC-network serves for damping the IF-filter while adjusting the other one.

MAIN BOARD - CIRCUIT DIAGRAM

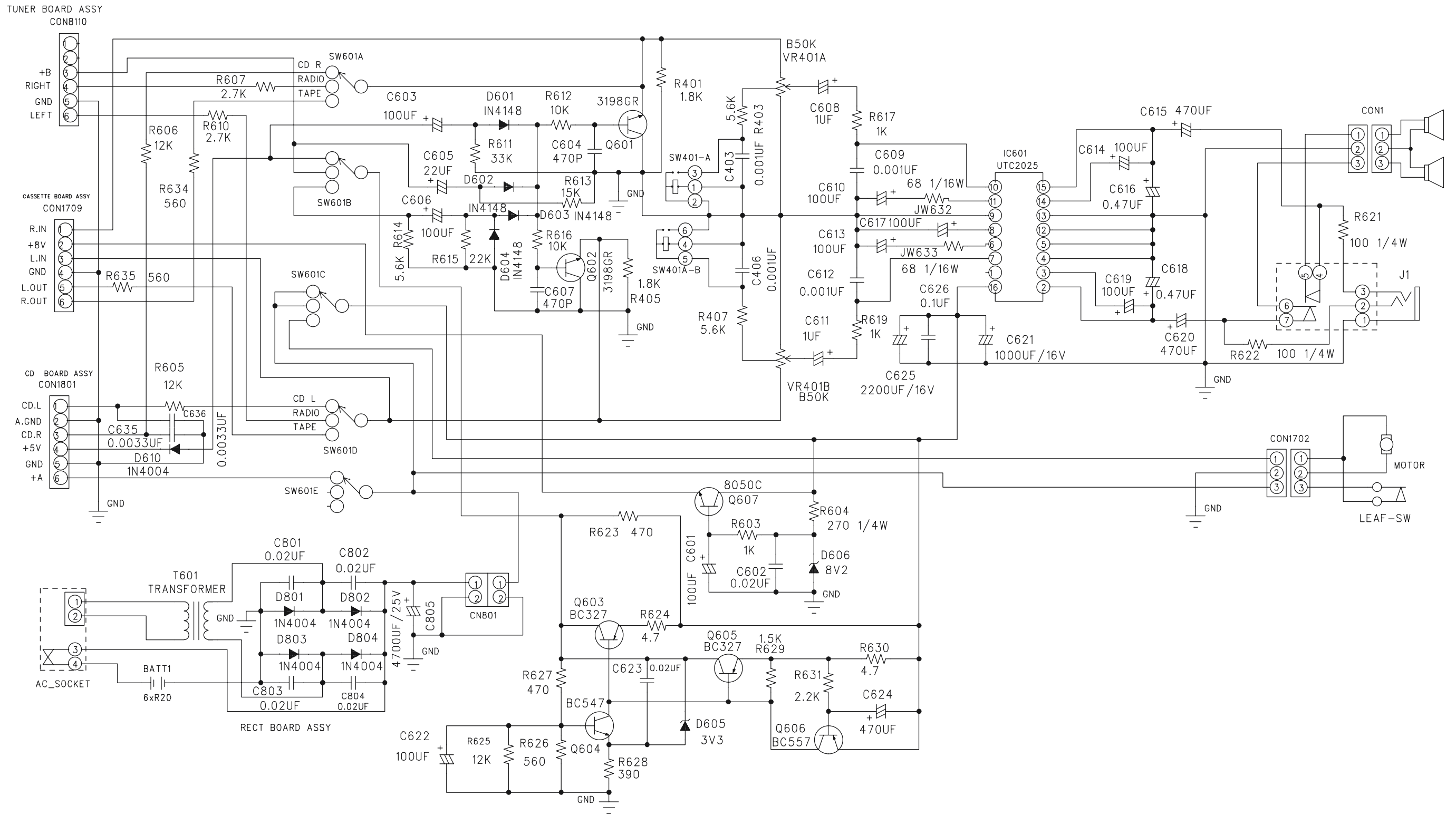

MAIN BOARD - LAYOUT DIAGRAM

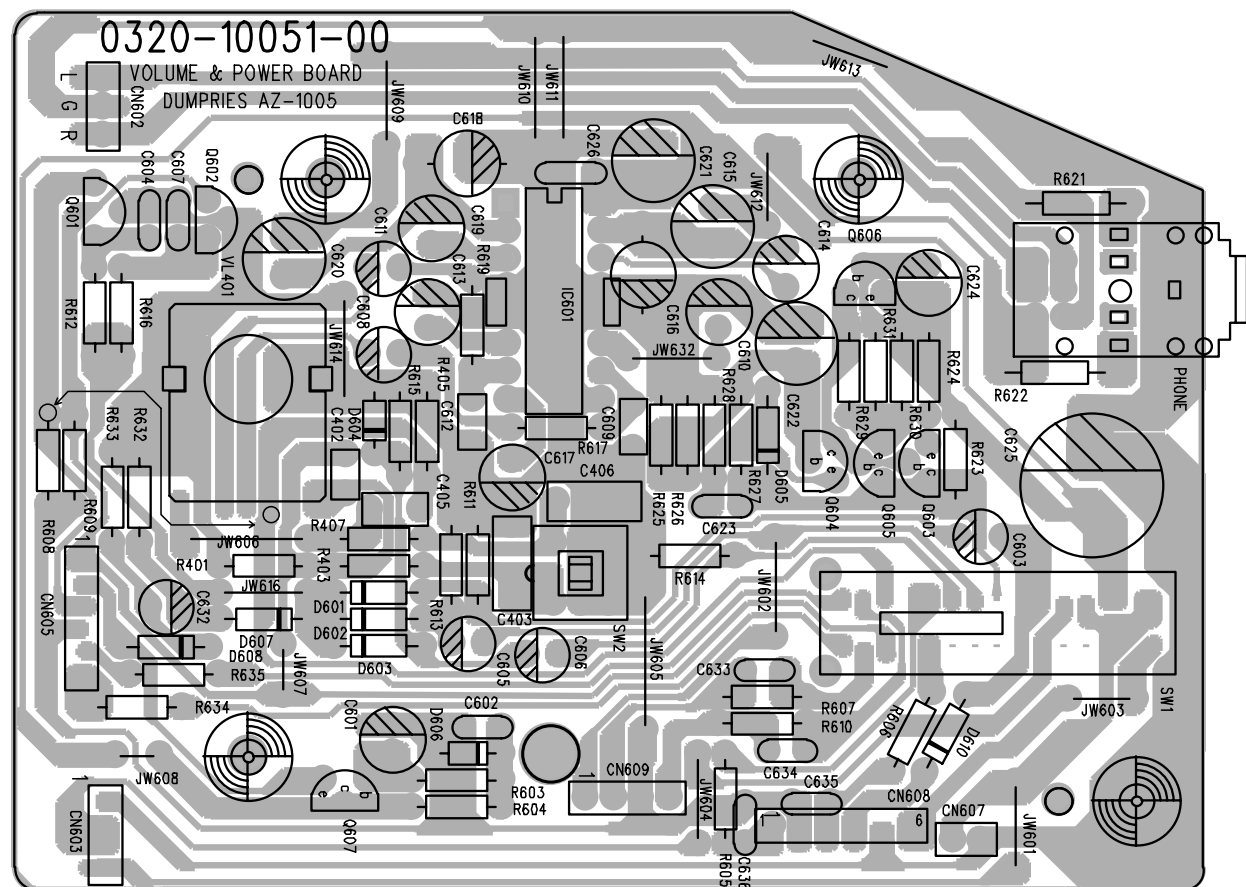

RECTIFIER BOARD - LAYOUT DIAGRAM

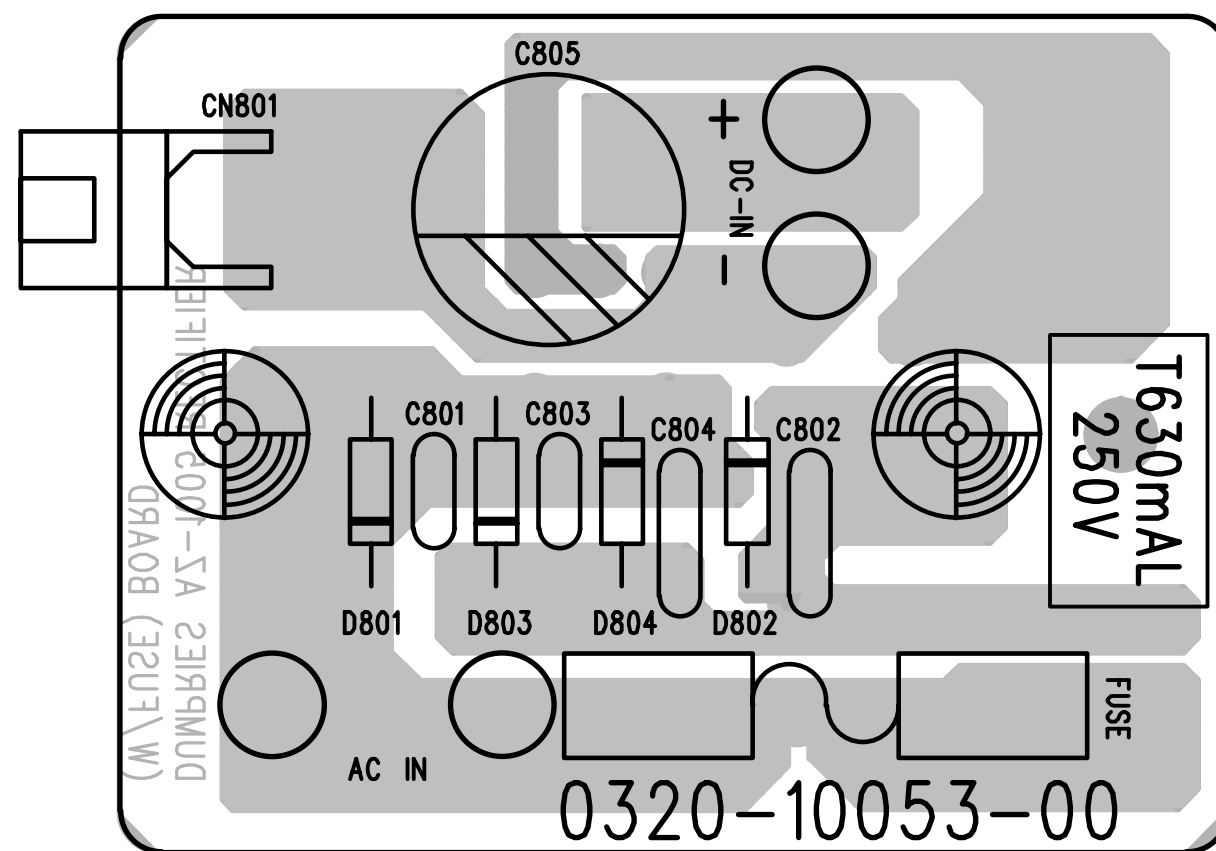

CASSETTE BOARD - CIRCUIT DIAGRAM

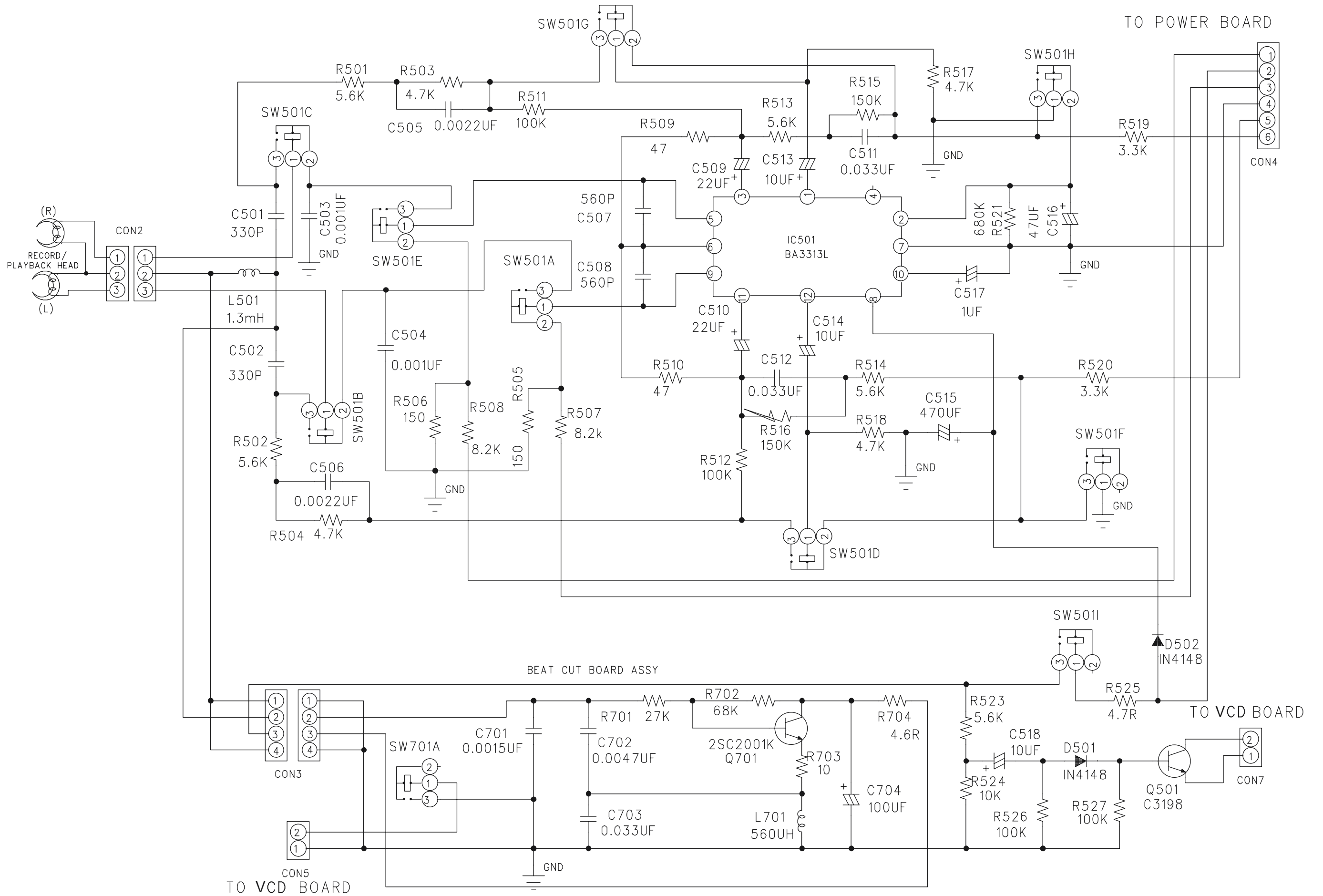

CASSETTE BOARD - LAYOUT DIAGRAM

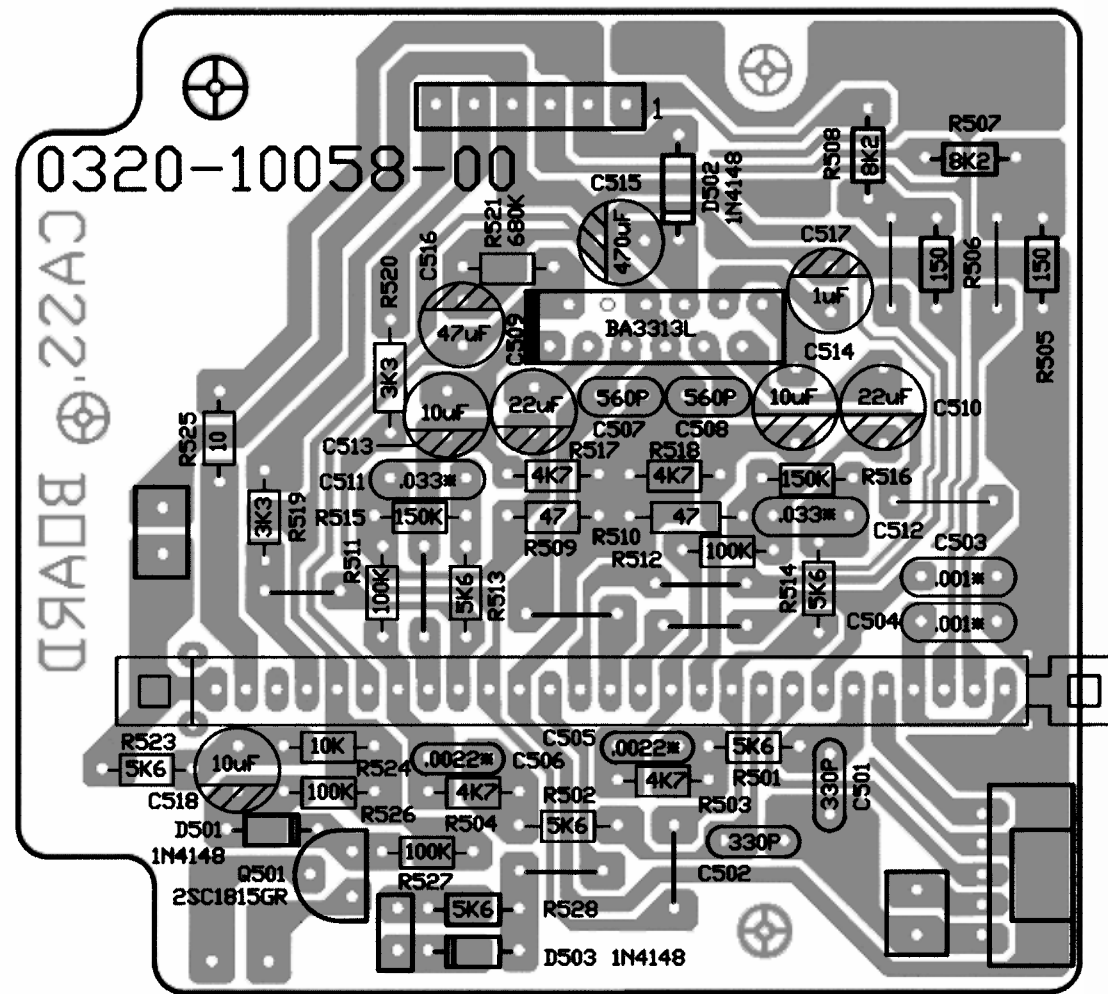

CASSETTE BOARD - ADJUSTMENT

Adjustment	Cassette	SK	Deck 1	Measure on	Read on	Adjust with	Adjust to
Azimuth	6.3 kHz	Tape	Play	H/P Jack	mV meter	Loose screw of R/P head	max.
Motor Speed	3 kHz (Mtt-111N OR EQUV)	Tape	Play	H/P Jack	Wow and flutter meter	Preset VR	** a

** a The maximum permissible speed deviation is 3%.
Moreover, the wow and flutter value can be read.

VCD BOARD - CIRCUIT DIAGRAM

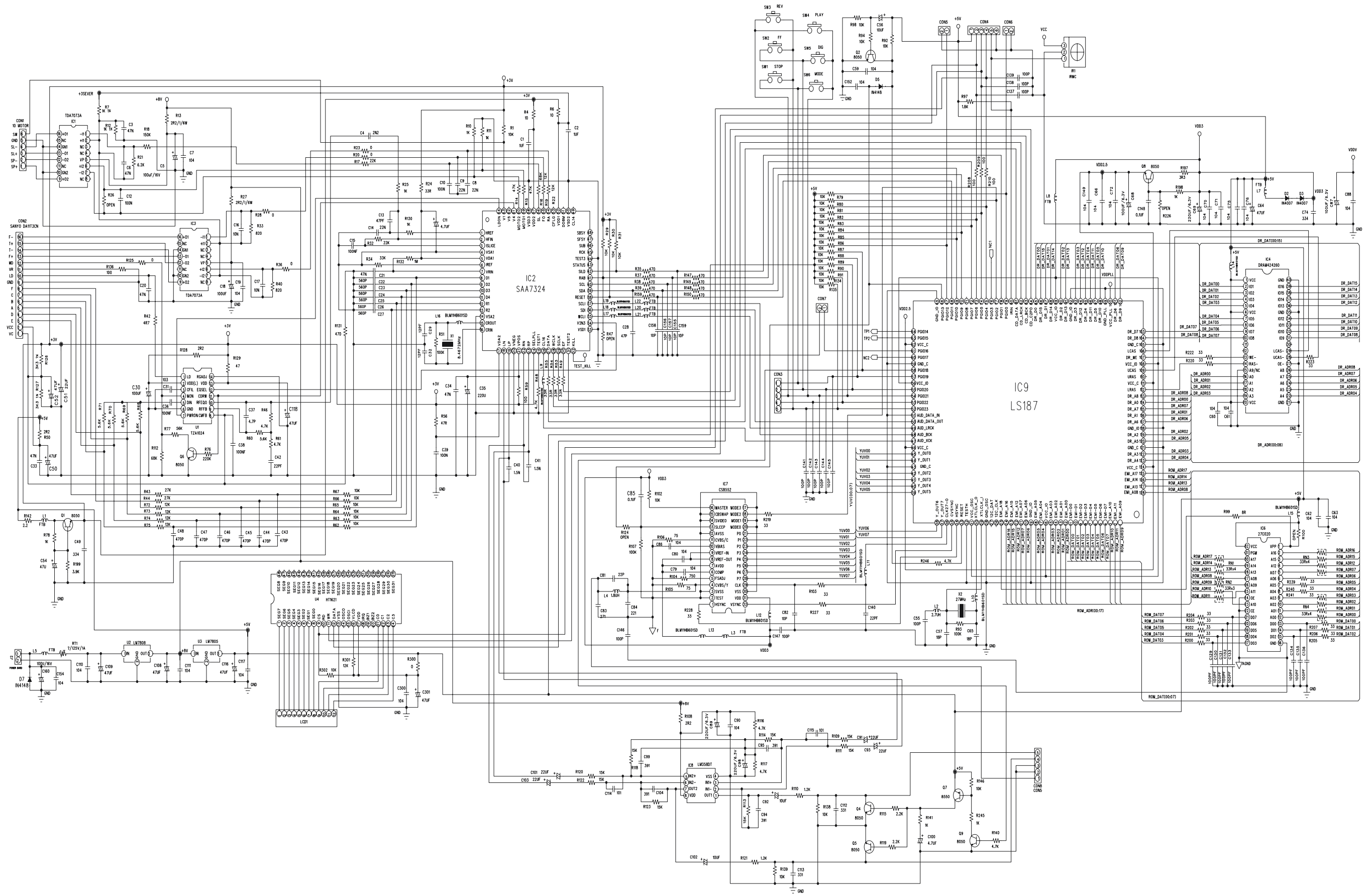

VCD BOARD - LAYOUT DIAGRAM
COMPONENT SIDE VIEW

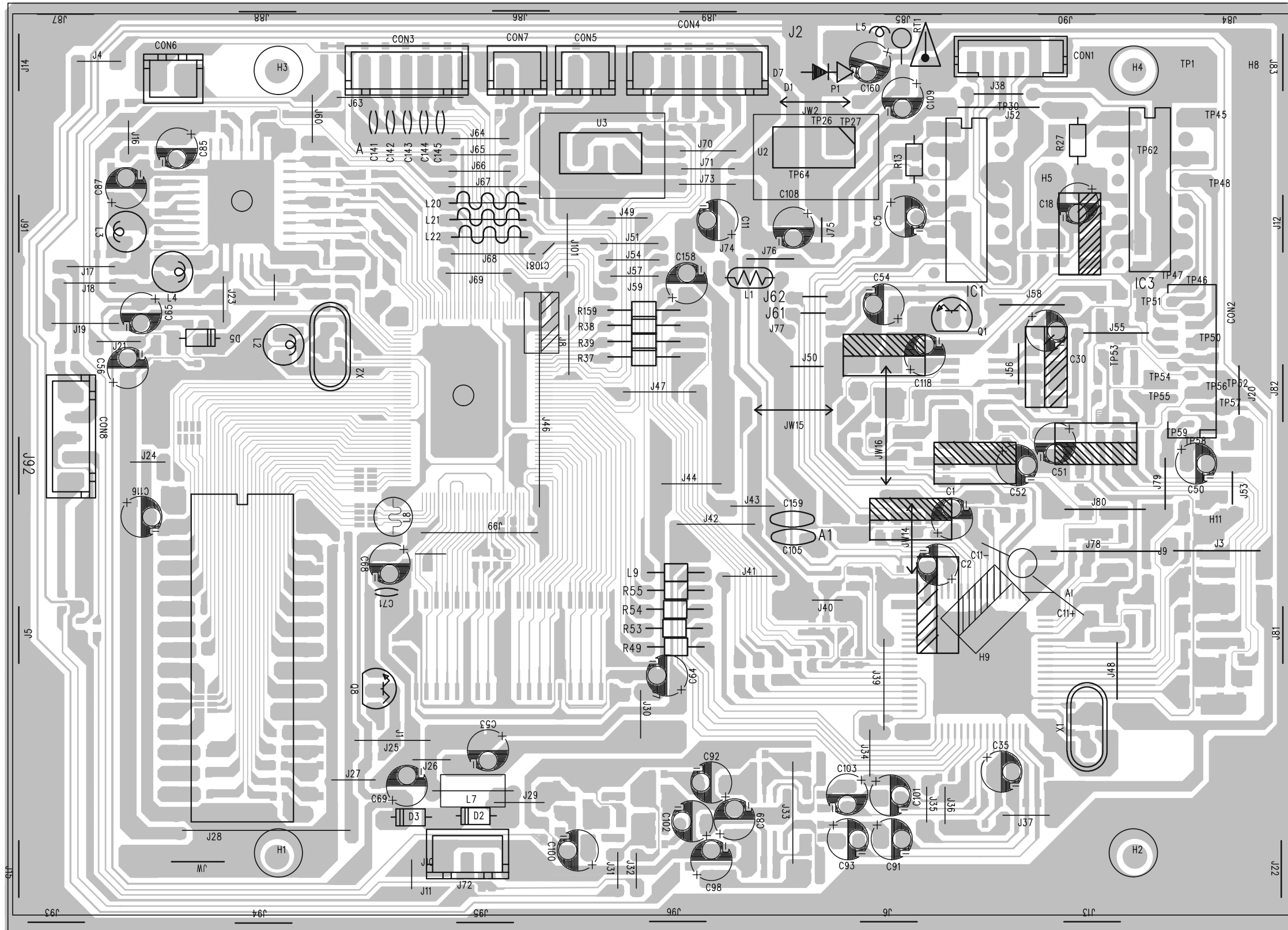
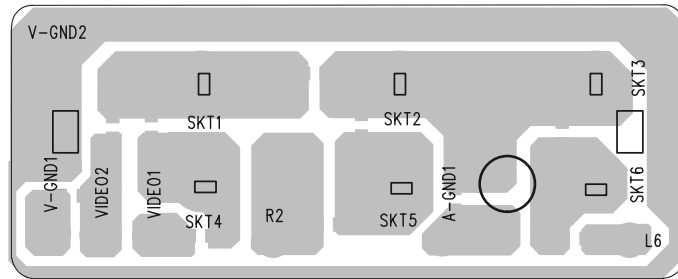

EXPLODED VIEW DIAGRAM - CABINET

SCREW LIST :

①	C M2 x 3
②	C M2 x 5
③	C 2 x 8
④	C M2.6 x 5
⑤	C 2.6 x 8
⑥	C M3 x 8
⑦	C 3 x 8
⑧	C 3 x 10
⑨	C 3 x 12
⑩	C 3 x 14
⑪	C 3 x 35
⑫	C P/W 3 x 10
⑬	C P/W 3 x 14

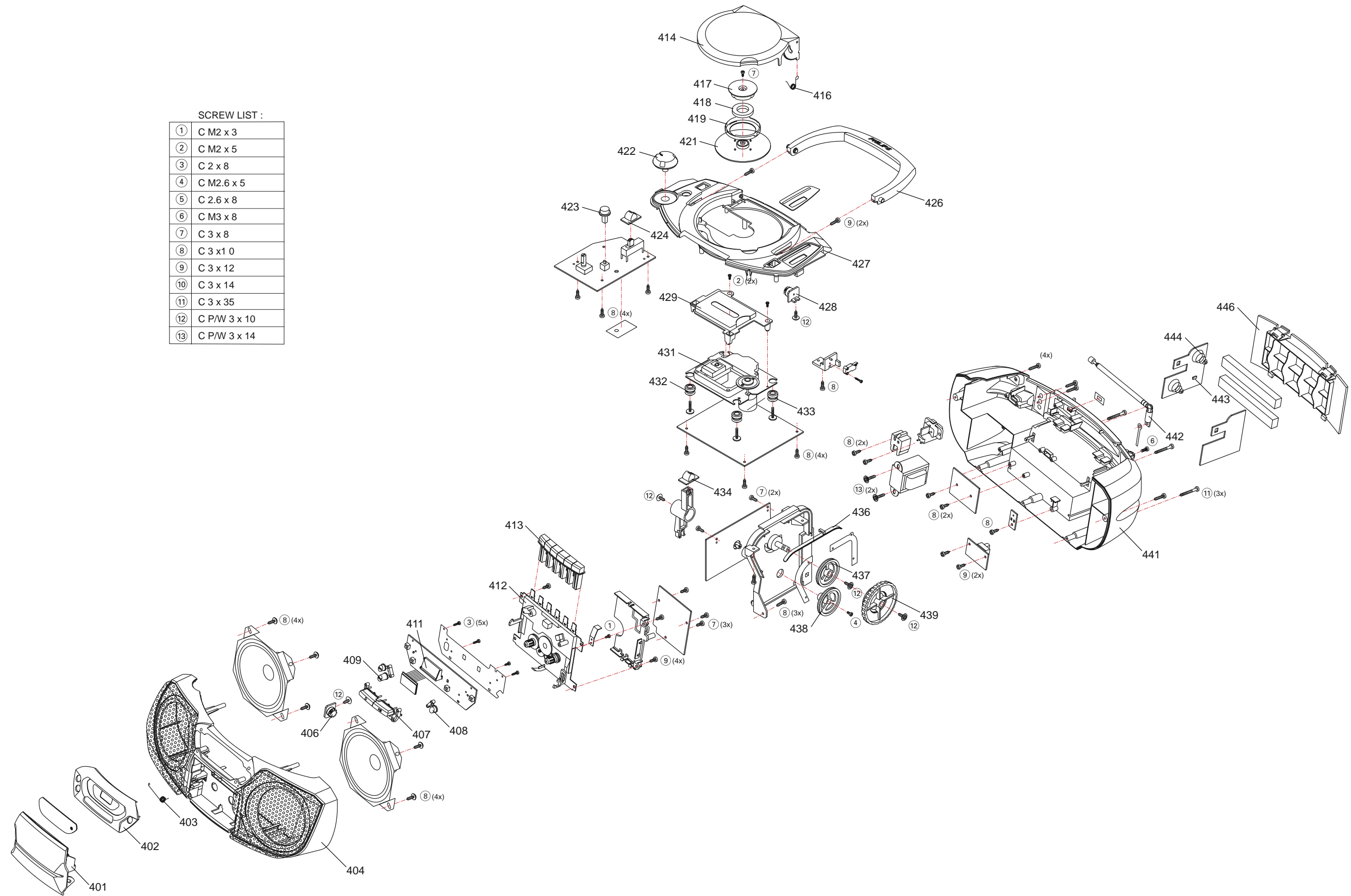

MECHANICAL PARTSLIST - CABINET

401	9965 000 14246	CASSETTE DOOR
402	9965 000 14247	FRONT CONTROL PANEL
403	9965 000 03342	CASSETTE DOOR SPRING
404	9965 000 14242	FRONT CABINET
406	4822 522 10778	CASSETTE DOOR GEAR
407	9965 000 14249	CD KNOB SET A
408	9965 000 14232	CD KNOB SET B(MODE)
409	9965 000 14231	CD KNOB SET B(REW/F.F.)
411	4822 402 11365	LCD BRACKET
412	9965 000 14240	TAPE DECK TK20FX-V682-001
413	9965 000 14251	CASSETTE KNOB KIT
414	9965 000 14244	CD DOOR
416	4822 492 11201	CD DOOR SPRING
417	4822 256 10586	CHUCKING PLATE HOLDER
418	4822 526 10731	MAGNET
419	4822 532 13163	CHUCKING PLATE RING
421	4822 466 12255	CHUCKING PLATE
422	9965 000 14236	VOLUME KNOB
423	9965 000 14237	DBB KNOB
424	9965 000 14235	FUNCTION KNOB
426	9965 000 14245	HANDLE
427	9965 000 14243	TOP PANEL
428	4822 522 10777	CD DOOR GEAR
429	4822 442 01905	LENS COVER
431	9965 000 14241	DA11T3CN
432	4822 529 10386	DAMPER - RUBBER (30 DEG)
433	4822 529 10387	DAMPER - RUBBER (40 DEG)
434	9965 000 14234	BAND KNOB
436	4822 450 10688	DIAL POINTER
437	4822 522 10776	CONNECTOR GEAR

MECHANICAL PARTSLIST - TAPE DECK

32	4822 403 20244	Roller Arm Assy
41	4822 358 31323	F. Belt
55	4822 358 31322	Main Belt
58	4822 403 71219	Eject Belt
62	4822 249 10475	R/P Head
63	4822 249 10531	E. Head
64	4822 361 21599	Motor EG-530AD-2B

Note : Only those parts mentioned in the list are normal service parts.

Note : Only those parts mentioned in the list are normal service parts.

EXPLODED VIEW DIAGRAM - TAPE DECK

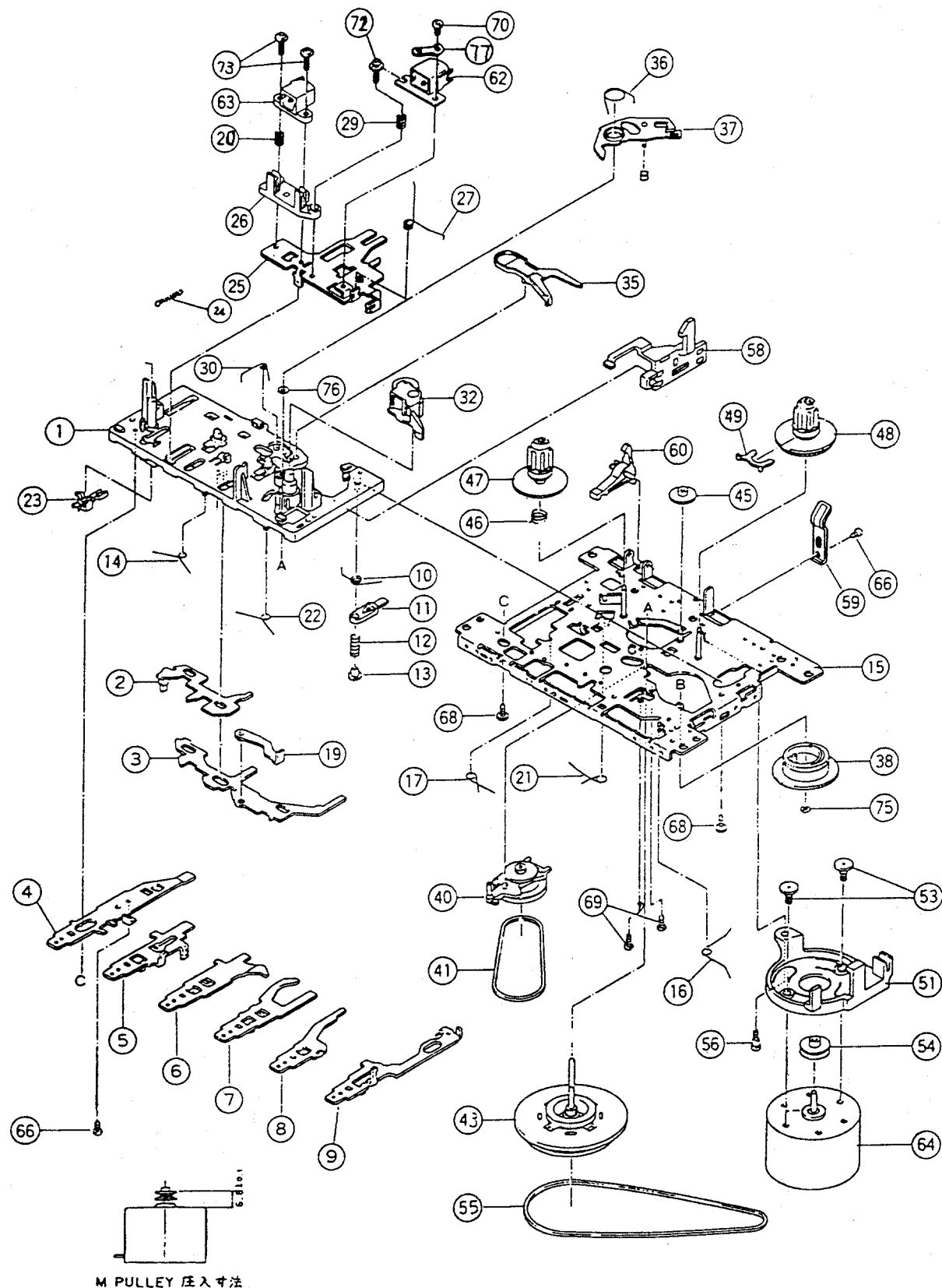

ELECTRICAL PARTSLIST - COMBI BOARD**- MISCELLANEOUS -**

SW1	4822 276 13443	SWITCH-PUSH
SW2	4822 276 13443	SWITCH-PUSH
SW3	4822 276 13443	SWITCH-PUSH
SW4	4822 276 13443	SWITCH-PUSH
SW6	4822 276 13443	SWITCH-PUSH
LCD	9965 000 14264	LCD 92093TR-P
CON2	9965 000 14266	FFC CONNECTOR 16P
	9965 000 14267	CABLE 16P
	9965 000 14268	RCA JACK RS-314-03
⚠	9965 000 14269	FUSE 1A 125V
X1	9965 000 14270	CRYSTAL 8,4672 MHZ
X2	9965 000 14271	CRYSTAL 27MHZ
L01	9965 000 14272	FERRITE BEAD
L1	9965 000 14272	FERRITE BEAD
L20	9965 000 14272	FERRITE BEAD
L21	9965 000 14272	FERRITE BEAD
L22	9965 000 14272	FERRITE BEAD
L5	9965 000 14272	FERRITE BEAD
L7	9965 000 14272	FERRITE BEAD
L8	9965 000 14272	FERRITE BEAD
	4822 277 21783	SWITCH
SW501	4822 276 13784	SWITCH-PUSH
J1	4822 267 31889	CONNECTOR
SW601	4822 277 11885	SLIDE SWITCH
SW401	4822 276 13972	PUSH SWITCH
	9965 000 10684	FERRITE BAR
1102	9965 000 14463	SLIDE SWITCH
⚠	9965 000 08577	AC SOCKET
	4822 277 30971	SWITCH
T601	⚠ 9965 000 14471	TRANSFORMER 120/230V
⚠	2422 070 98151	MAINS CORD SET
	4822 240 10392	SPEAKER 4" 8OHM

- RESISTORS -

RN1	9965 000 14461	33 R
RN2	9965 000 14461	33 R
RN3	9965 000 14461	33 R
RN4	9965 000 14461	33 R
R704	9965 000 10676	PTC DC 4,6 OHM
VR401	4822 101 11967	50K
3101	4822 101 11292	50K

- COILS & FILTERS -

L02	4822 157 11074	100µH
L03	4822 157 11074	100µH
L04	4822 157 11074	100µH
L10	4822 157 11074	100µH
L11	4822 157 11074	100µH

- COILS & FILTERS -

L12	4822 157 11074	100µH
L13	4822 157 11074	100µH
L14	4822 157 11074	100µH
L15	4822 157 11074	100µH
L16	4822 157 11074	100µH
L17	4822 157 11074	100µH
L18	4822 157 11074	100µH
L19	4822 157 11074	100µH
L2	9965 000 14273	COIL
L4	9965 000 14274	1,8 µH COIL
L9	4822 157 11074	100µH
L701	4822 157 70806	560µH
L501	9965 000 14462	CHOKE COIL
	4822 070 31602	FUSE 1,6A
5101	9965 000 14464	FM COIL
5102	9965 000 14465	AM COIL
5104	9965 000 14466	FM COIL
5105	9965 000 14467	IFT MW
5106	9965 000 14468	IFT MW
5107	9965 000 14469	KMFC5058-Z
5108	9965 000 14470	MW IF2

- DIODES -

D1	4822 130 30621	1N4148
D2	5322 130 34574	1N4004G
D3	5322 130 34574	1N4004G
D4	4822 130 30621	1N4148
D5	4822 130 30621	1N4148
D6	4822 130 30621	1N4148
D7	4822 130 31438	1N4001G
D8	9965 000 08563	3,9V 1/2W
D501	4822 130 30621	1N4148
D502	4822 130 30621	1N4148
D601	4822 130 30621	1N4148
D602	4822 130 30621	1N4148
D603	4822 130 30621	1N4148
D604	4822 130 30621	1N4148
D605	4822 130 11665	HZS3C3
D606	4822 130 10493	DIODE 8,2V
D610	5322 130 34574	1N4004G
D801	5322 130 34574	1N4004G
D802	5322 130 34574	1N4004G
D803	5322 130 34574	1N4004G
D804	5322 130 34574	1N4004G
6101	4822 130 30621	1N4148
6102	4822 130 30621	1N4148

ELECTRICAL PARTSLIST - COMBI BOARD**- IC & TRANSISTORS -**

IR1	9965 000 14265	RPM6938-V4
Q1	4822 130 62718	JE8050C
Q2	9965 000 14275	HMBT8050
Q3	4822 130 62718	JE8050C
Q4	9965 000 14275	HMBT8050
Q5	9965 000 14275	HMBT8050
Q6	9965 000 14275	HMBT8050
Q7	9965 000 14276	HMBT8550
IC1	4822 209 32852	TDA7073A/N2
IC2	9352 641 80557	SAA7324H/M2B
IC3	4822 209 32852	TDA7073A/N2
IC4	9965 000 14336	IC41C16256-35K
IC5	9965 000 14340	LS187
IC6	9965 000 14341	AT27C020-70PC
IC7	9965 000 14342	CS8552
IC8	5322 209 82941	LM358D
U1	4822 209 17286	TZA1024T/N1
U2	9965 000 14343	KIA7808P
U3	9965 000 14344	KA7805
Q701	4822 130 60258	2SC2001K
Q501	4822 130 63773	KTC3198-GR
IC501	4822 209 33988	BA3313L
Q601	4822 130 63773	KTC3198-GR
Q602	4822 130 63773	KTC3198-GR
Q603	4822 130 41327	BC327-40
Q604	4822 130 44503	BC547C
Q605	4822 130 41327	BC327-40
Q606	4822 130 42231	BC557C
Q607	4822 130 63422	8050B
IC601	4822 209 17541	UTC2025
7101	4822 209 32746	TEA5711T/N2

Note: Only these parts mentioned in the list are normal service parts.